



Model : 27/2021



# P-47 Thunderbolt "Razorback"

**1200mm**

## Specs :

1. Wingspan 1200mm / 42.2 inches
2. Flying weight : 1150 grams/ 40.5 oz
3. Wing loading : 51.1 gram/dm<sup>2</sup> - 16.8 oz/sq.ft.
4. Wing cube loading : 10.8
5. Wing Area : 22.5 dm<sup>2</sup> / 349 sq.in.
6. CG : 7 cm from LE (wing root)

## Electronics

- Tested with Hobbyking 3536 650kv Brushless motor
- Recommended motor : 500-1200kv 35 motor
- 50A ESC
- Battery Lipo 3S 2200mah 70C (recommended using 4S)
- 4 x 9 gram servos (micro servo)
- Master Airscrew 11x5x3
- 85mm foam wheel
- servoless retractable landing gear

## Materials :

1. 5mm Foamboard/ Depron/ Polyfoam
2. 3mm + 9mm Plywood
3. 0.3mm Mica Plastic
4. hot glue, UHU glue, CA glue
5. packing tapes / laminating film

## Build Instructions :

1. [paper-replika.com](http://paper-replika.com)
2. youtube channel : Julius Perdana

**F1**

FUSELAGE  
POLYFOAM/  
DEPRON 5MM

JOIN HERE

JOIN HERE



F1

**F4**

FUSELAGE FORMER  
POLYFOAM/  
DEPRON 5MM



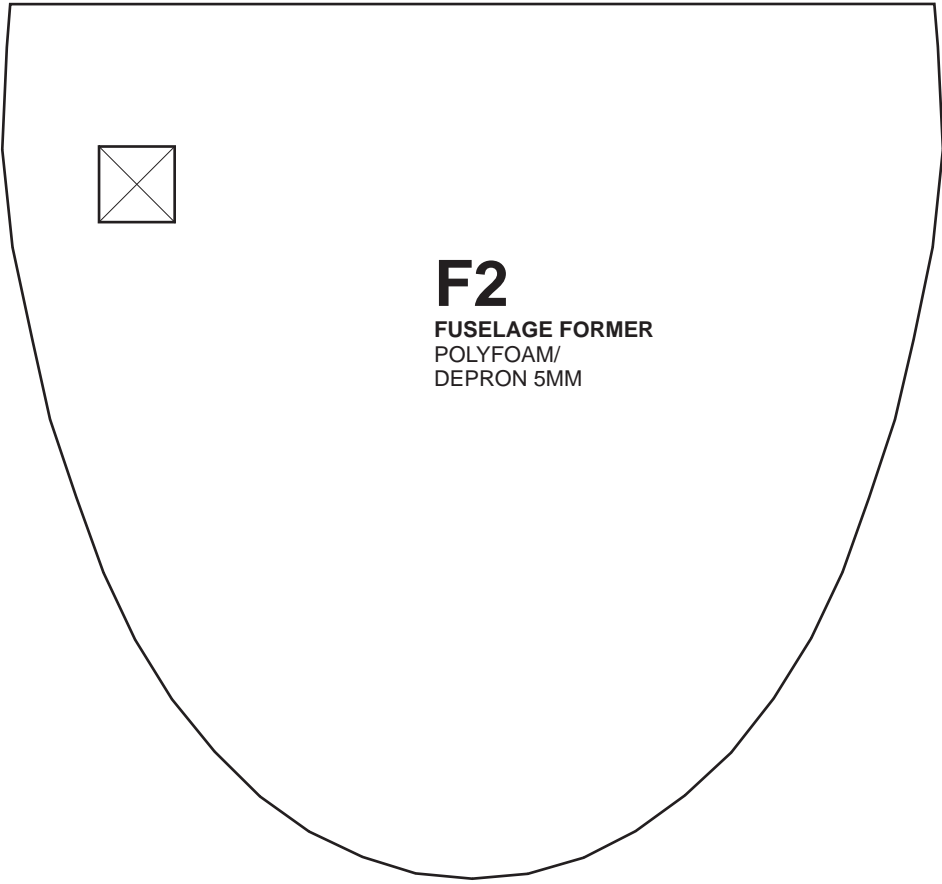

**F2**  
FUSELAGE FORMER  
POLYFOAM/  
DEPRON 5MM

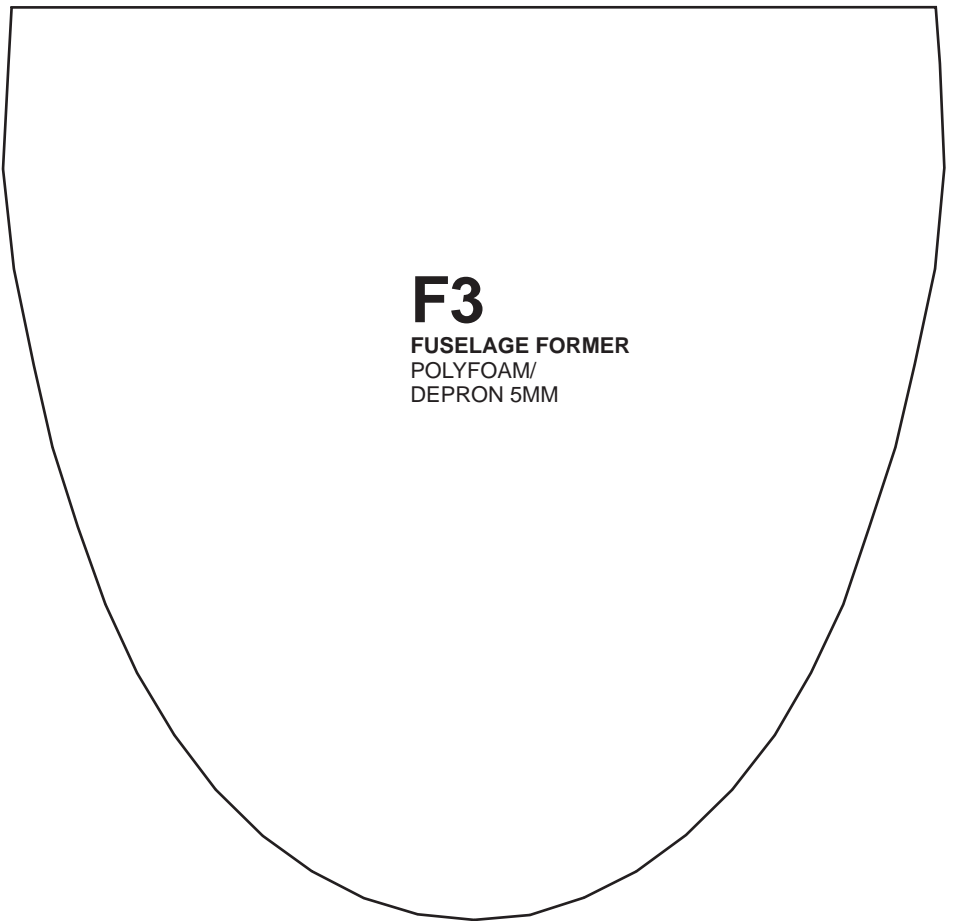

**F3**  
FUSELAGE FORMER  
POLYFOAM/  
DEPRON 5MM

**F7**

FUSELAGE FORMER  
POLYFOAM/  
DEPRON 5MM



**F5**

FUSELAGE FORMER  
POLYFOAM/  
DEPRON 5MM



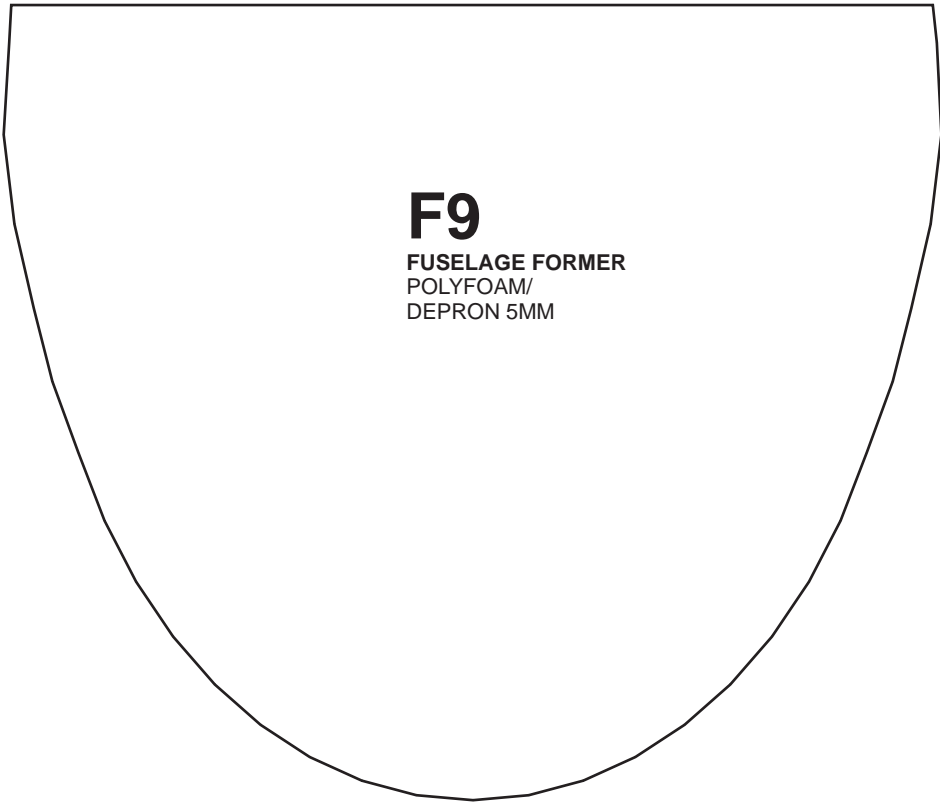
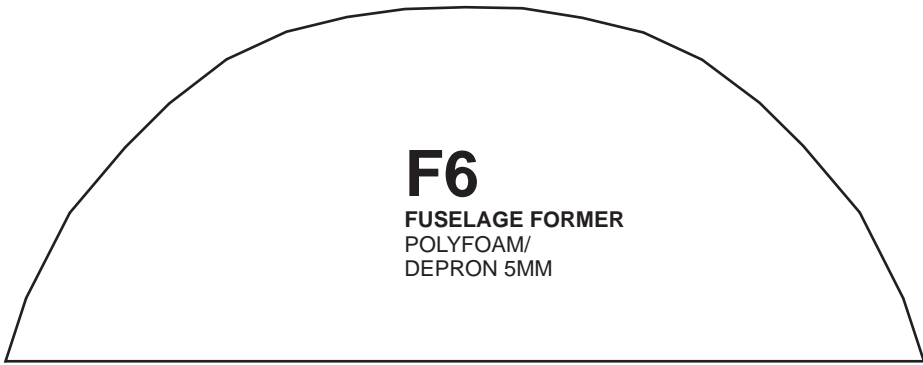



# F10

FUSELAGE FORMER  
POLYFOAM/  
DEPRON 5MM

**F8**

FUSELAGE  
POLYFOAM/  
DEPRON 5MM

JOIN HERE



IN HERE

F8



# F11

FUSELAGE  
POLYFOAM/  
DEPRON 5MM

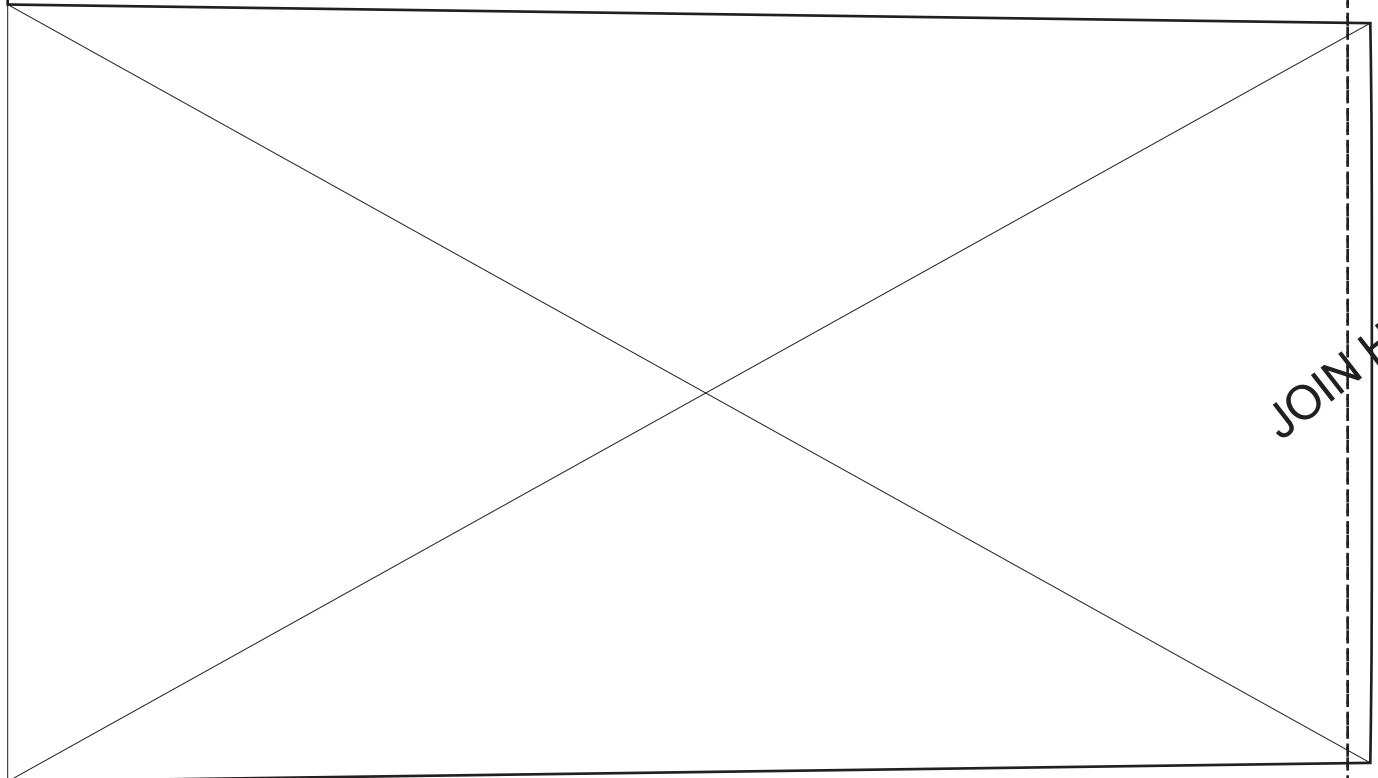

JOIN HERE

# F12

FUSELAGE FORMER  
POLYFOAM/  
DEPRON 5MM

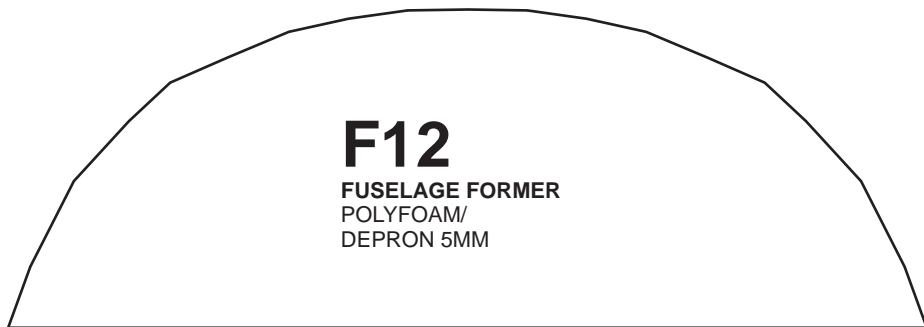

JOIN HERE

**F11**

JOIN HERE

**F13**

FUSELAGE  
POLYFOAM/  
DEPRON 5MM

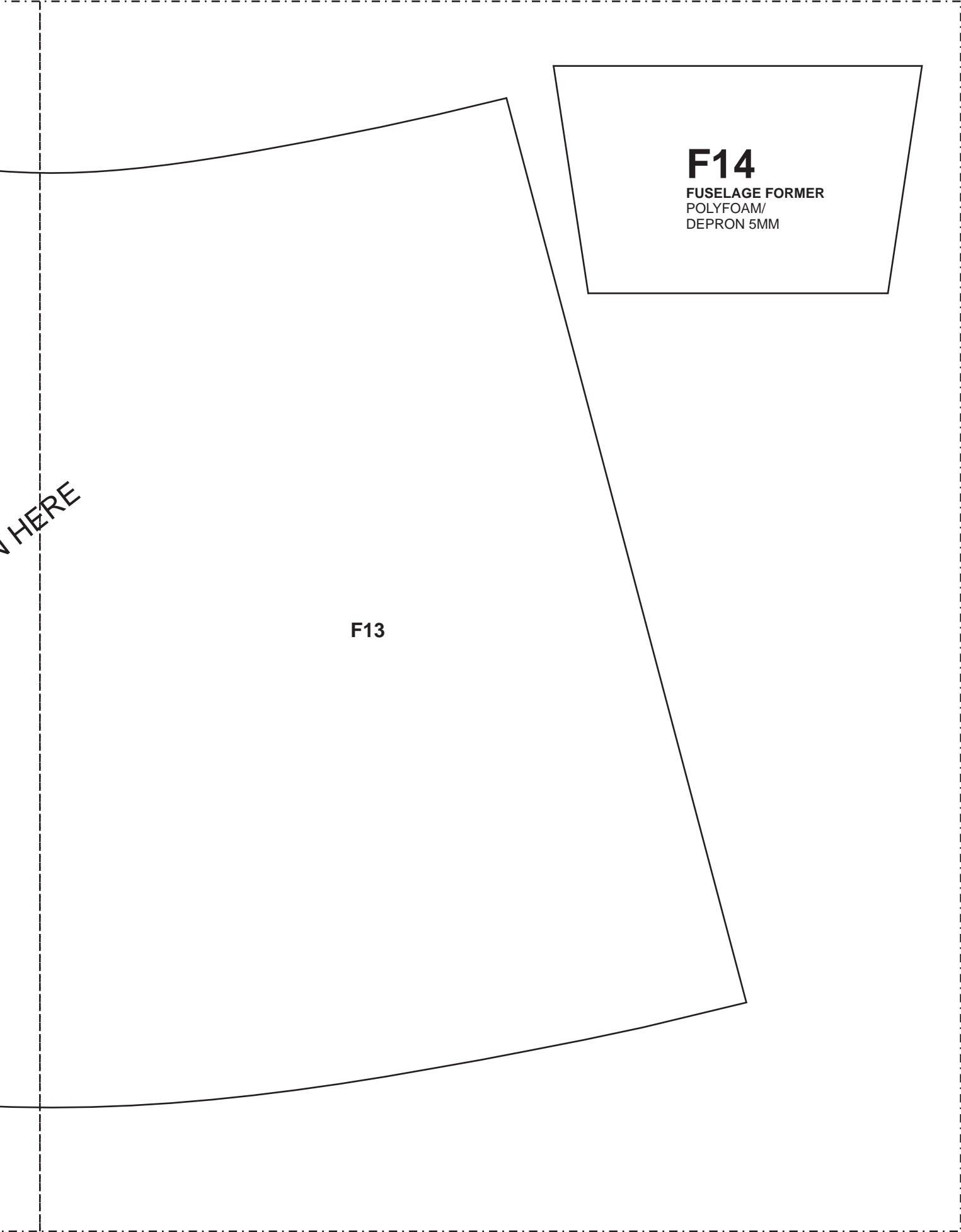

**F14**

FUSELAGE FORMER  
POLYFOAM/  
DEPRON 5MM

**F13**

HERE

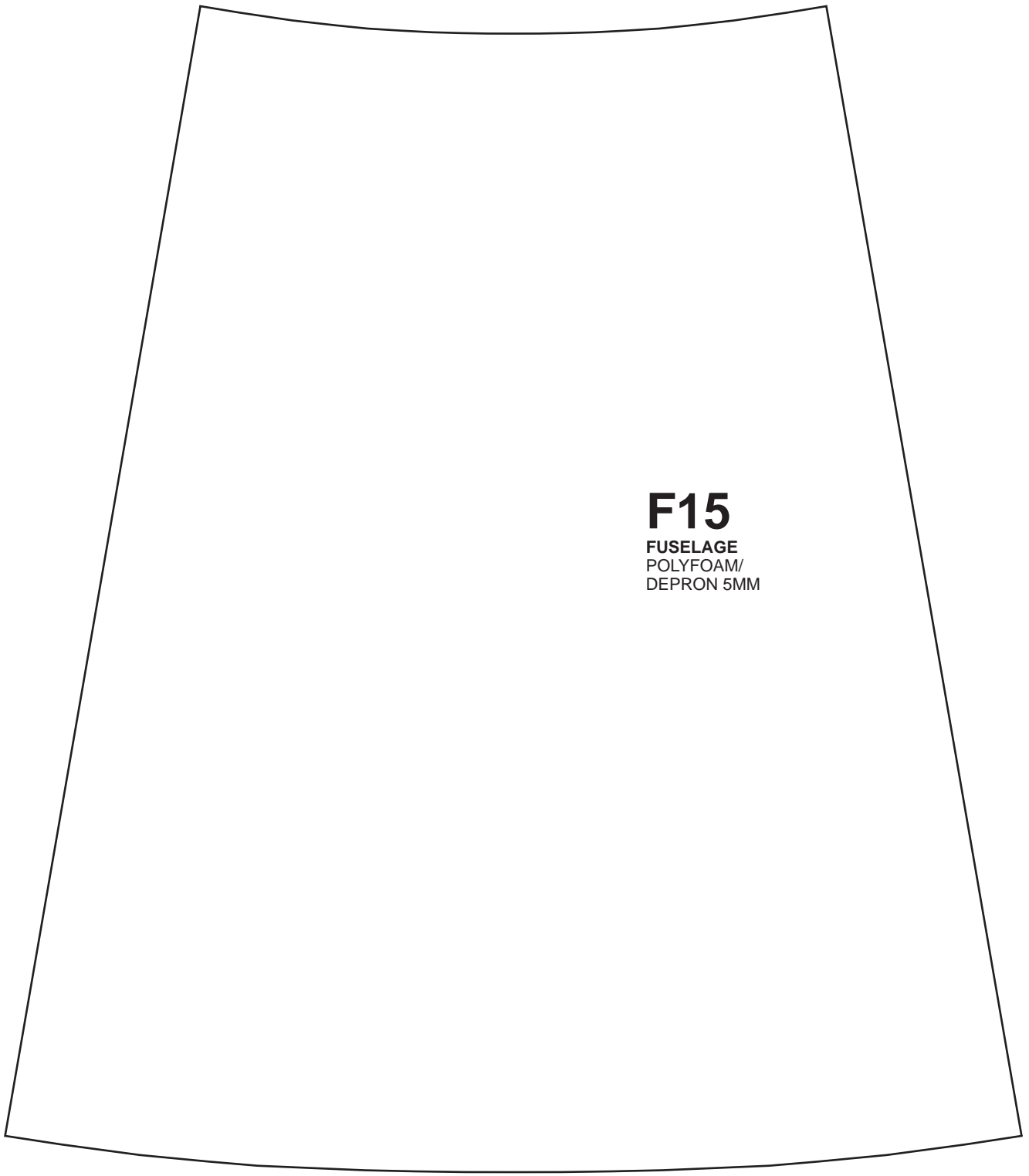

**F15**

FUSELAGE  
POLYFOAM/  
DEPRON 5MM



**F16**

FUSELAGE  
POLYFOAM/  
DEPRON 5MM

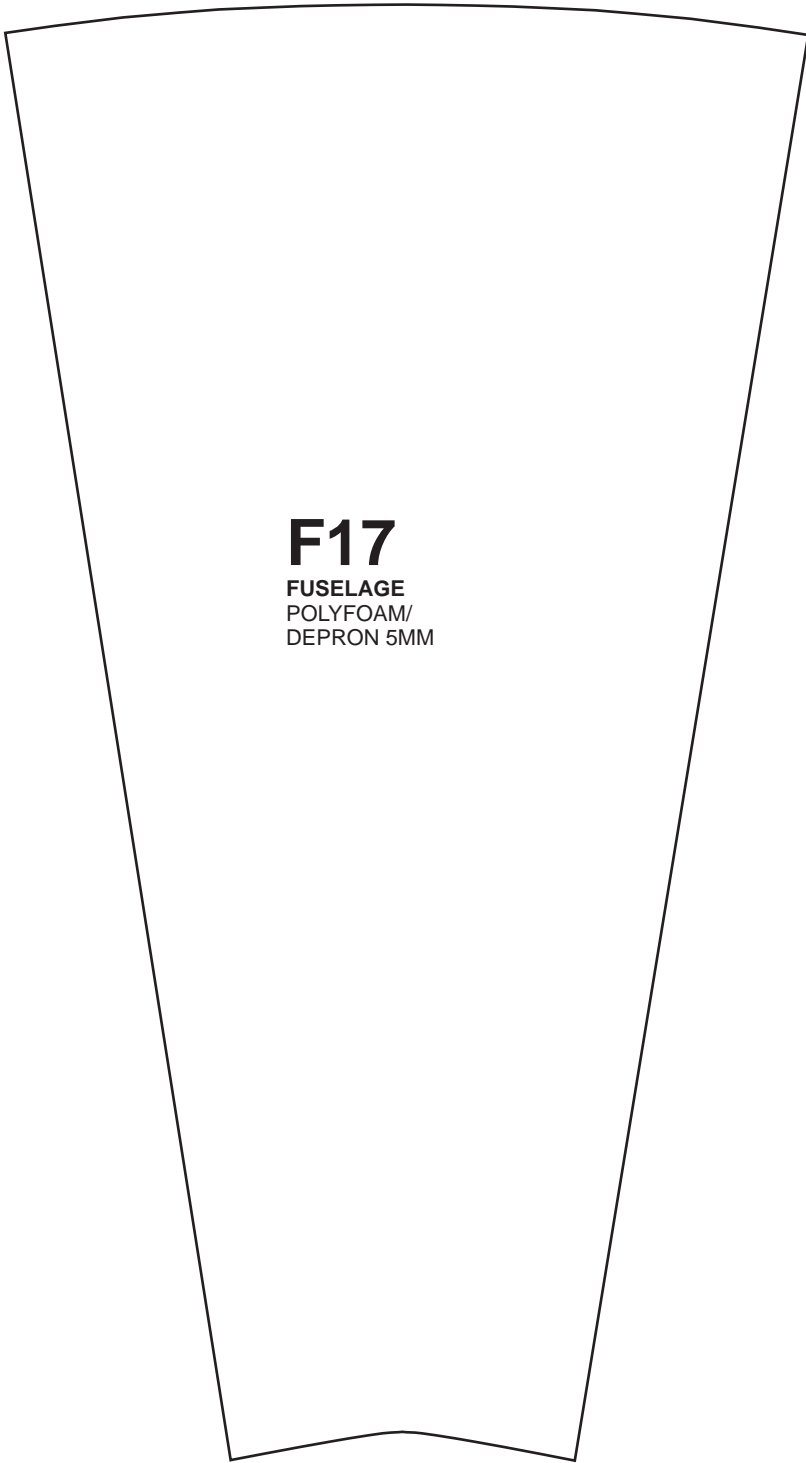

**F17**

FUSELAGE  
POLYFOAM/  
DEPRON 5MM



**F18**  
FUSELAGE  
POLYFOAM/  
DEPRON 5MM

JOIN HERE



JOIN HERE

F18

**F19**

FUSELAGE  
POLYFOAM/  
DEPRON 5MM





**F22**  
FUSELAGE  
POLYFOAM/  
DEPRON 5MM

JOIN HERE

JOIN HERE

F22



**F20**  
FUSELAGE  
POLYFOAM/  
DEPRON 5MM

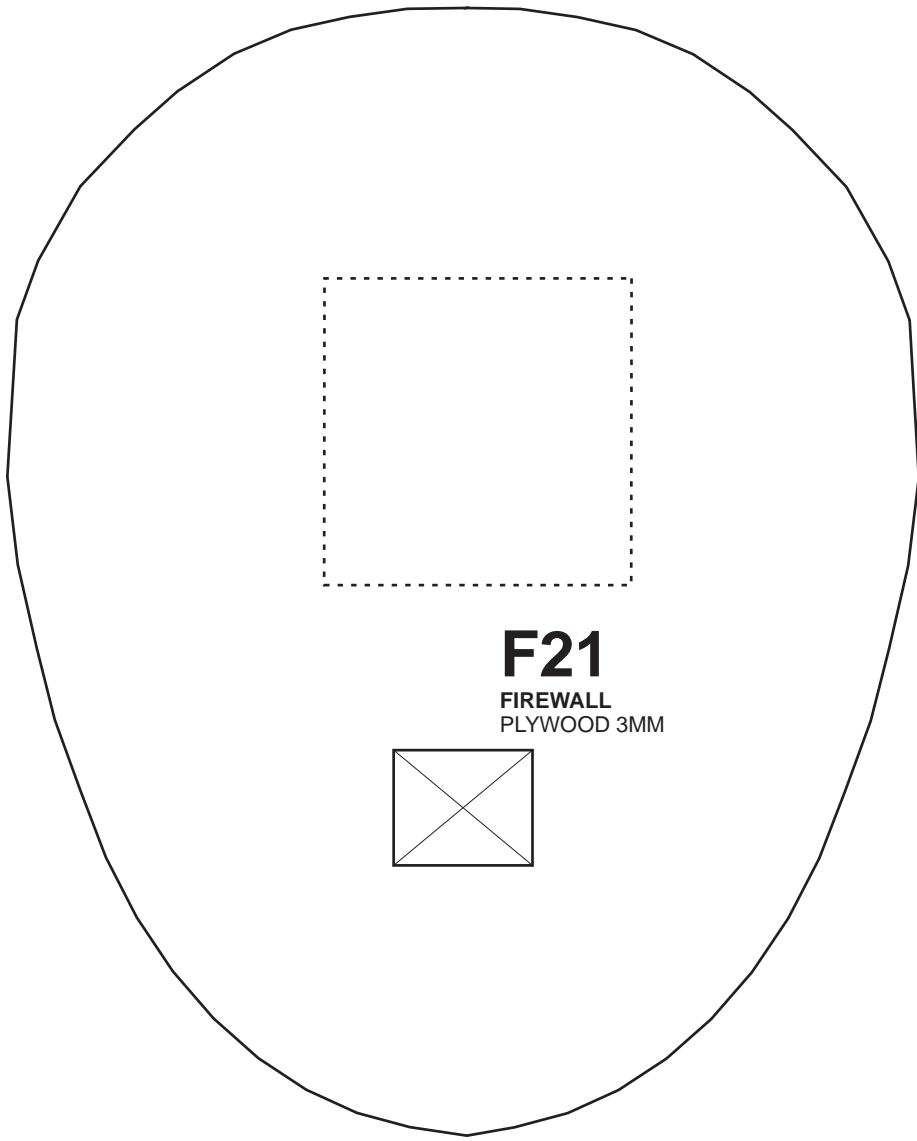

**F21**

FIREWALL  
PLYWOOD 3MM

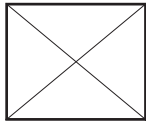

**F23**

**COWL**  
POLYFOAM/ DEPRON 5MM  
3X

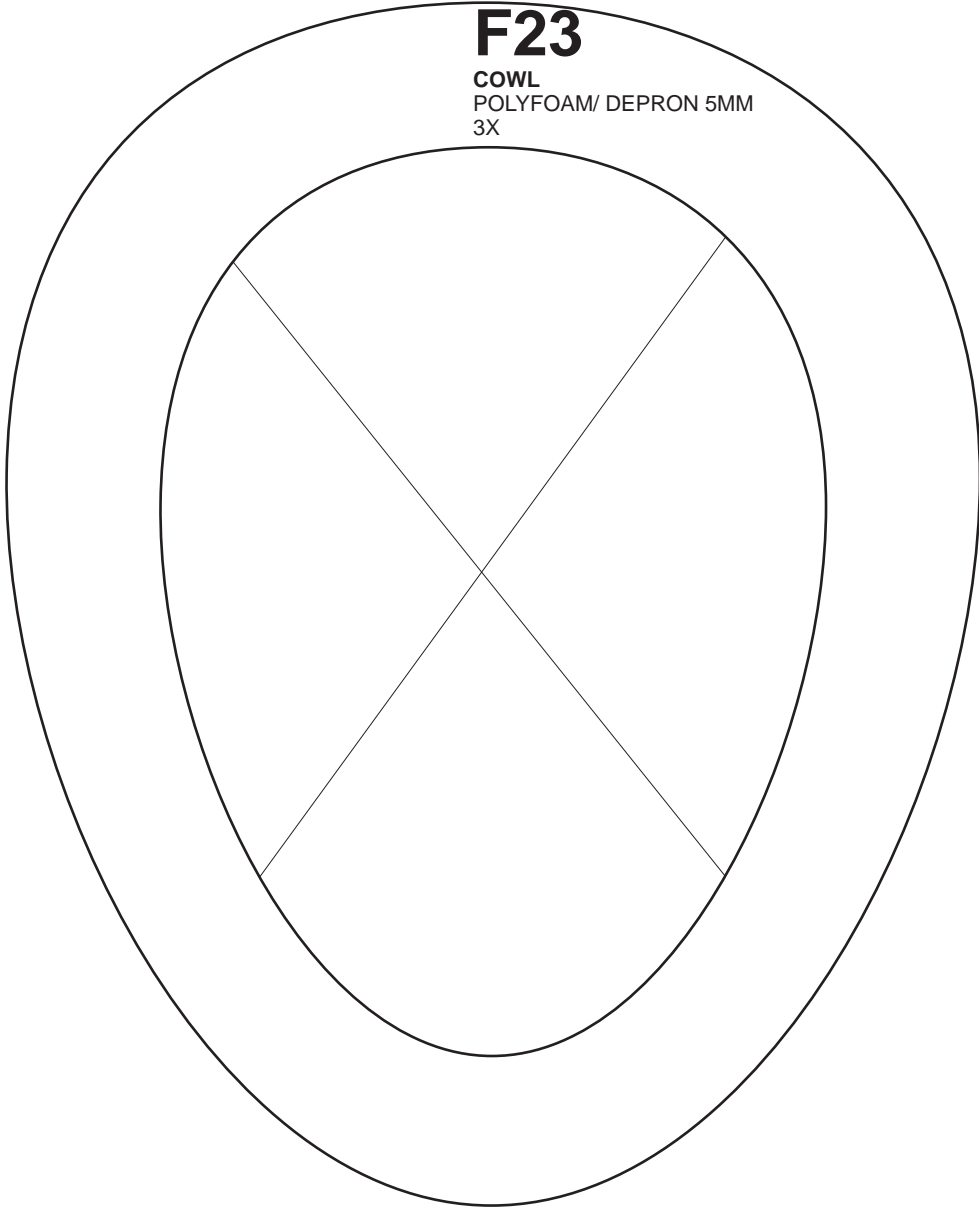

**W2**

**WING FORMER**  
POLYFOAM/  
DEPRON 5MM  
2X

**W1**

**WING**  
POLYFOAM/  
DEPRON 5MM  
2X MIRRORED

JOIN HERE

JOIN HERE

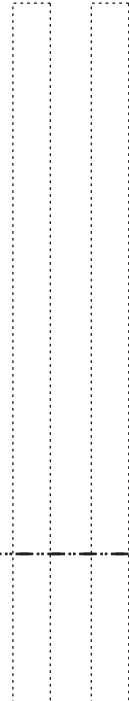

HERE

W1

JOIN HERE

**W6**

WING  
POLYFOAM/  
DEPRON 5MM  
2X

**W7**

LG  
PLYWOOD 9MM  
2X

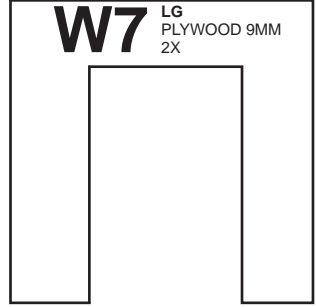

JOIN HERE

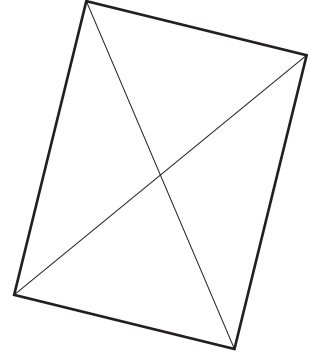

JOIN HERE



W1

JOIN HERE





JOIN HERE

JOIN HERE

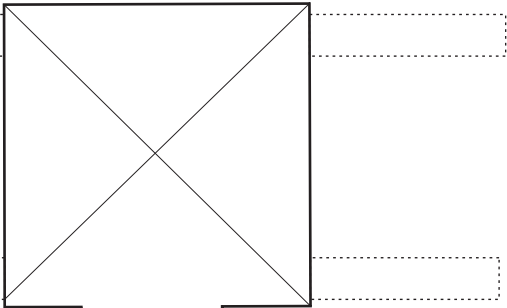

W1

**W5**

WING  
POLYFOAM/  
DEPRON 5MM  
4X

W3

W4

JOIN HERE

JOIN HERE

JOIN HERE

JOIN HERE

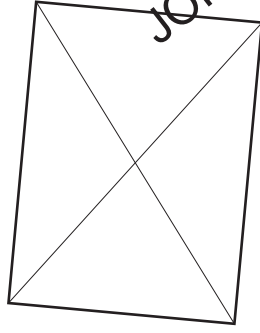

W1

JOIN HERE

JOIN HERE

JOIN HERE

JOIN HERE

**W1**

**W3**

WING SPAR  
POLYFOAM/  
DEPRON 5MM  
2X

**W4**

WING SPAR  
POLYFOAM/  
DEPRON 5MM  
2X

JOIN HERE

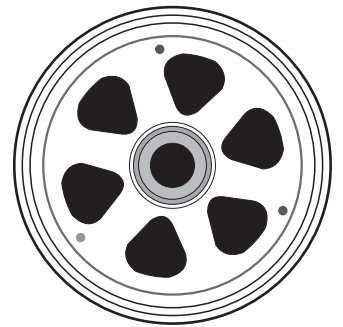
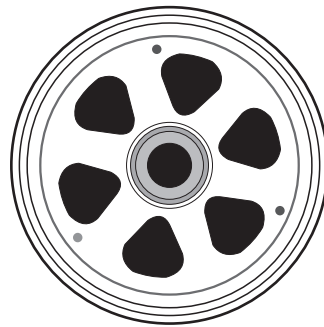
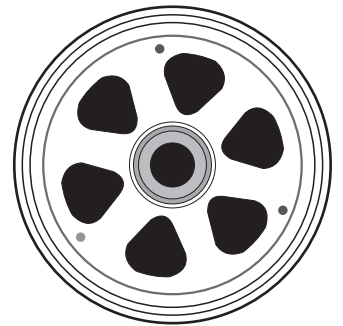
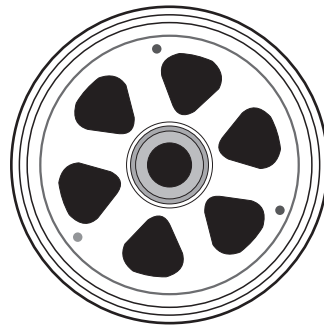
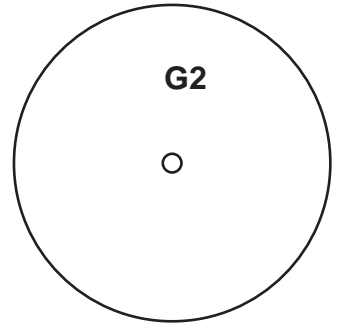
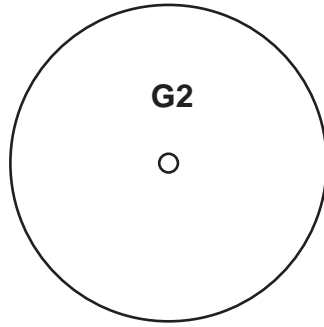
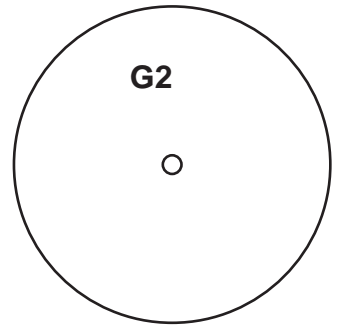
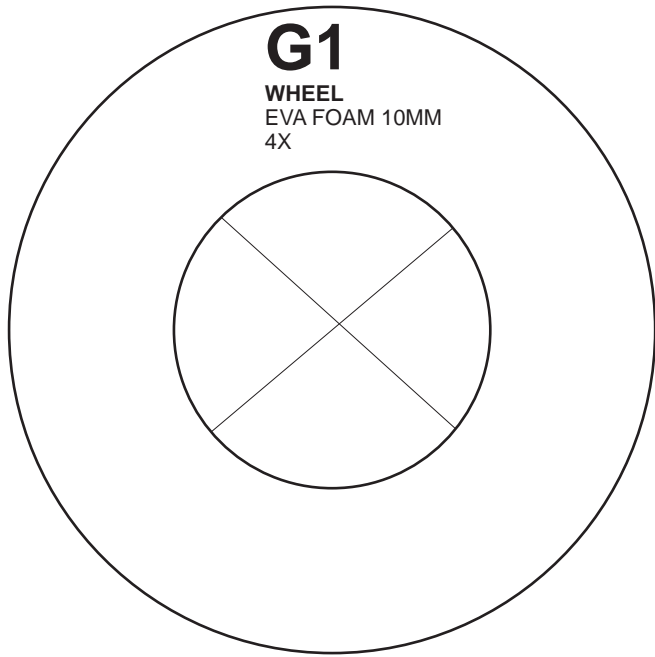

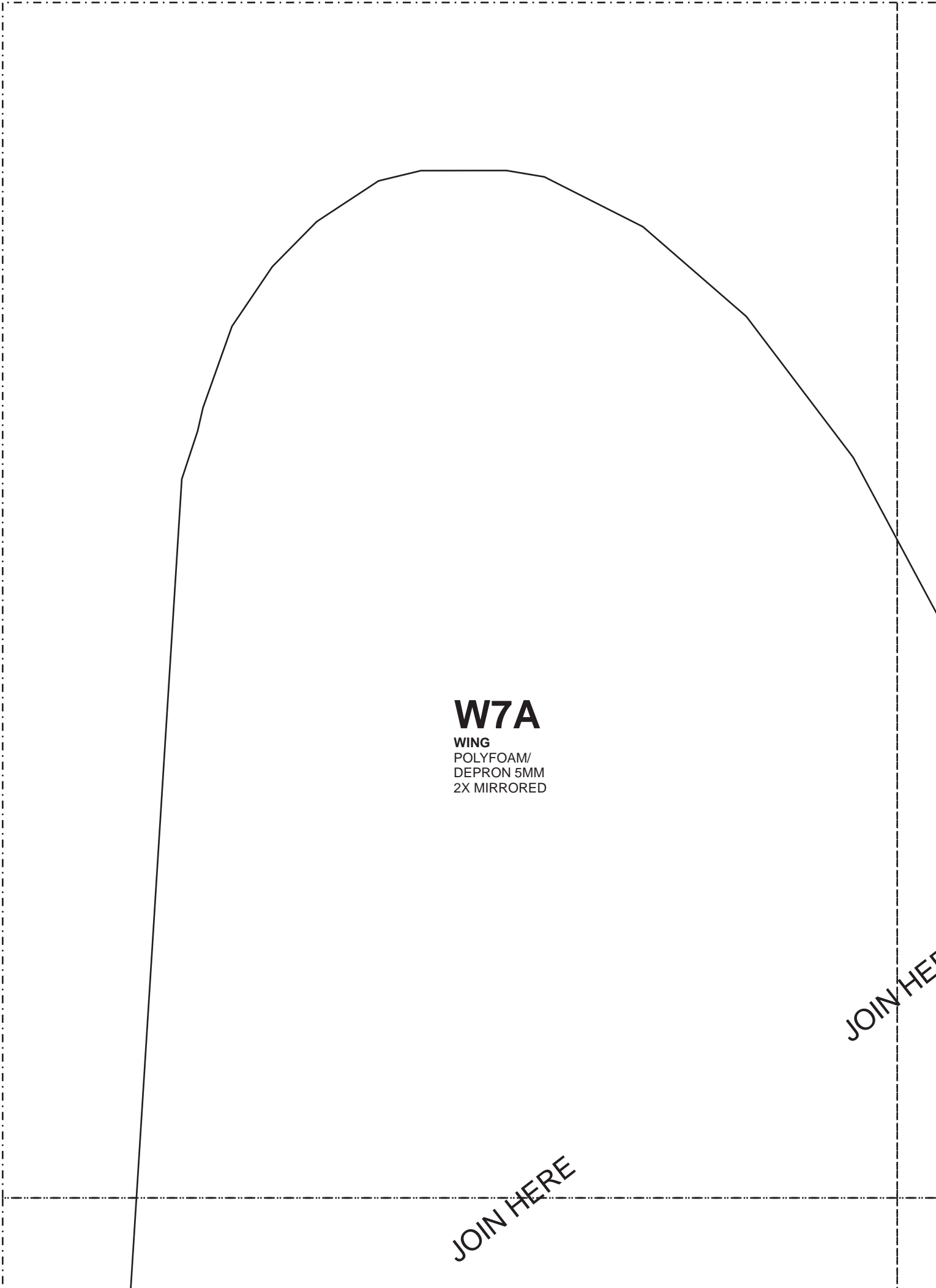

# W7A

WING  
POLYFOAM/  
DEPRON 5MM  
2X MIRRORED

JOIN HERE

JOIN HERE

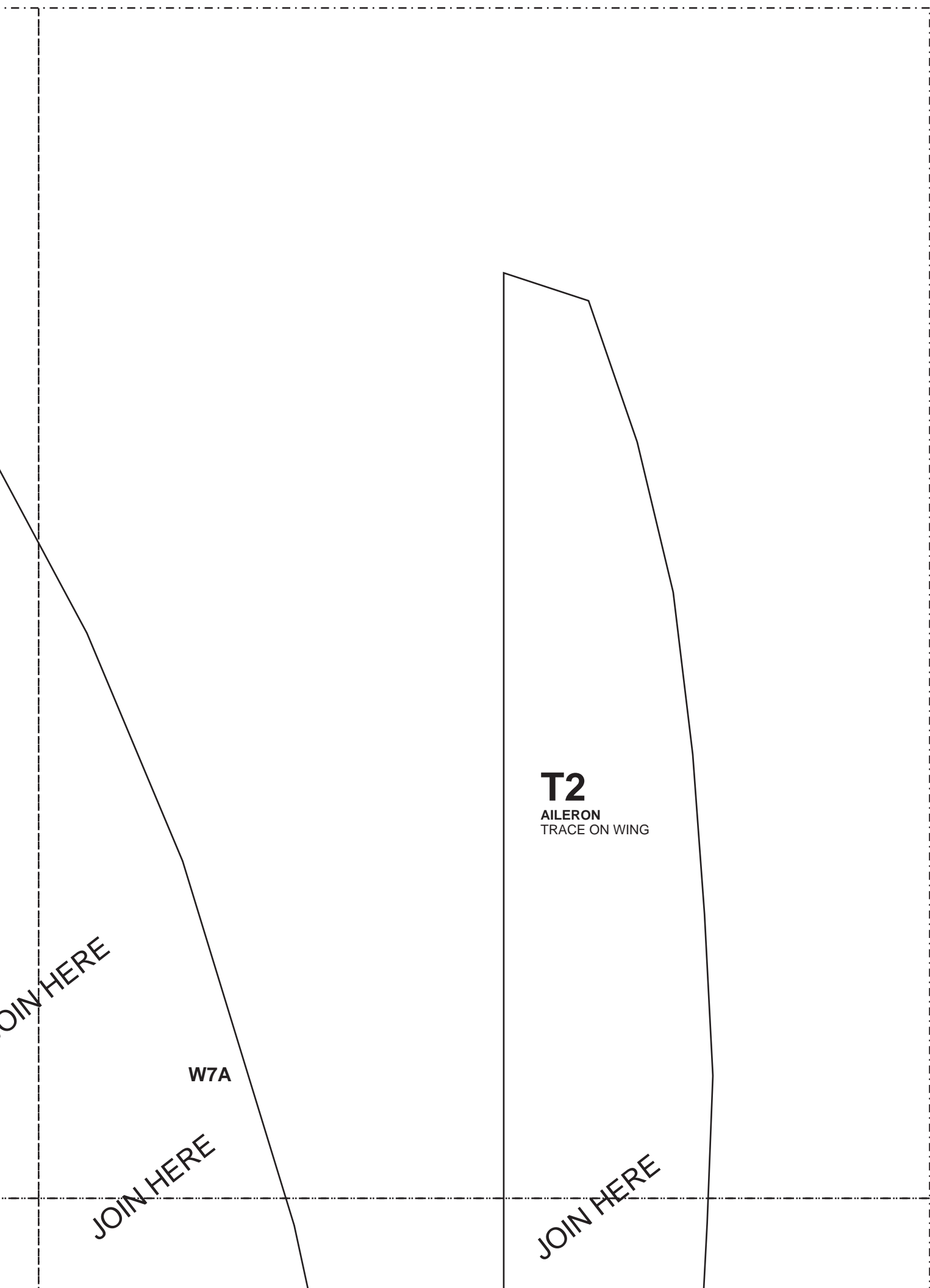

JOIN HERE

W7A

**T2**  
AILERON  
TRACE ON WING

JOIN HERE

JOIN HERE

JOIN HERE

W7A

JOIN HERE

JOIN HERE

JOIN HERE

JOIN HERE

JOIN HERE

W7A

**T1**  
FLAP  
TRACE ON WING

JOIN HERE

JOIN HERE



JOIN HERE

JOIN HERE

W7A

JOIN HERE

JOIN HERE

JOIN HERE

W7A

T1

JOIN HERE

**W8**

WING JOINER  
PLYWOOD  
3MM

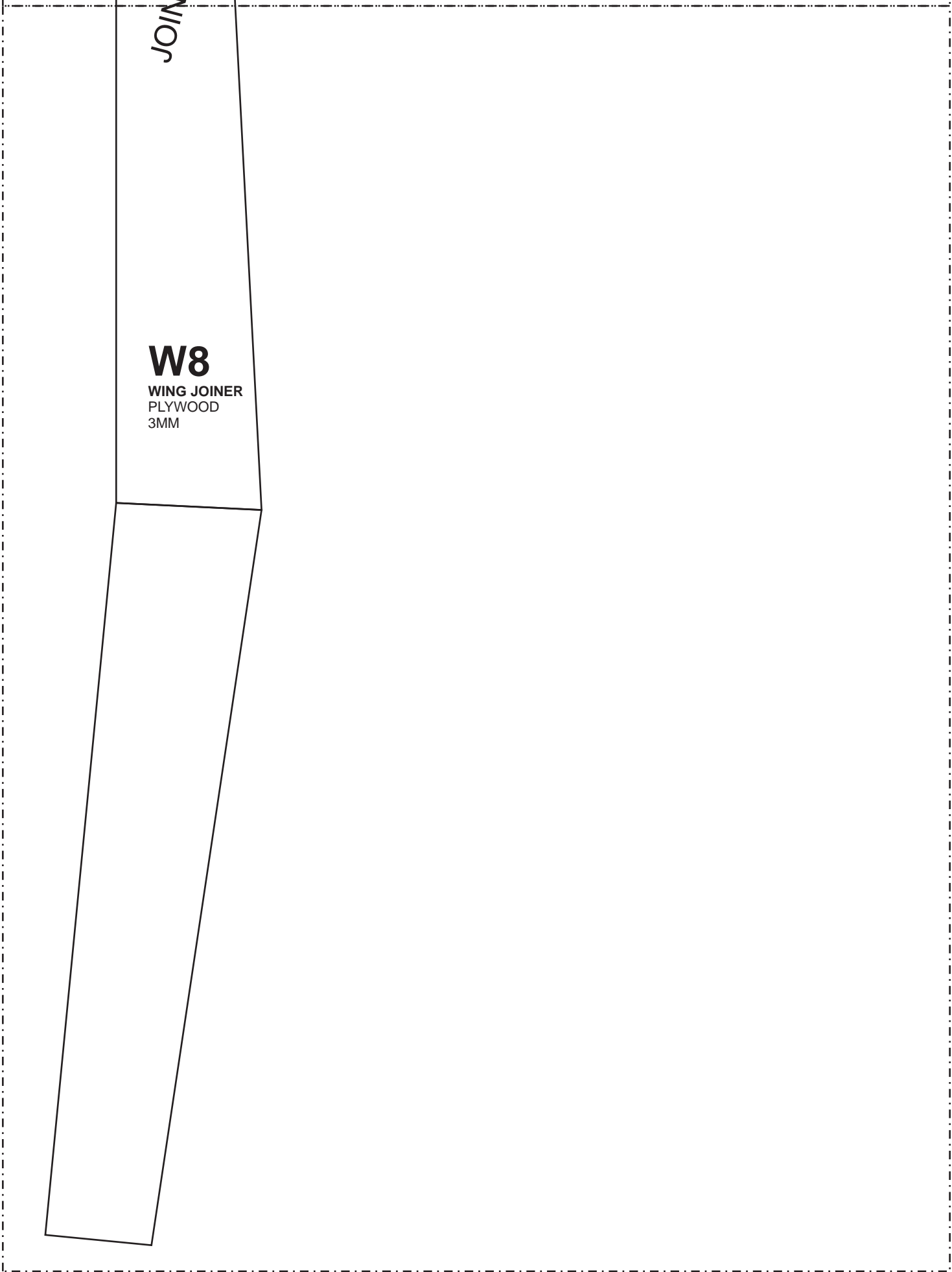

**F24**

WING MOUNT  
PLYWOOD  
9MM

**F24**

WING MOUNT  
PLYWOOD  
9MM

**F25**

WING MOUNT  
DEPRON/POLYFOAM 5MM  
4X

**W8**

JOIN HERE

**T4**

WING PLACEMENT  
TRACE ON FUSELAGE

JOIN HERE

**T5**

WING PLACEMENT  
TRACE ON FUSELAGE

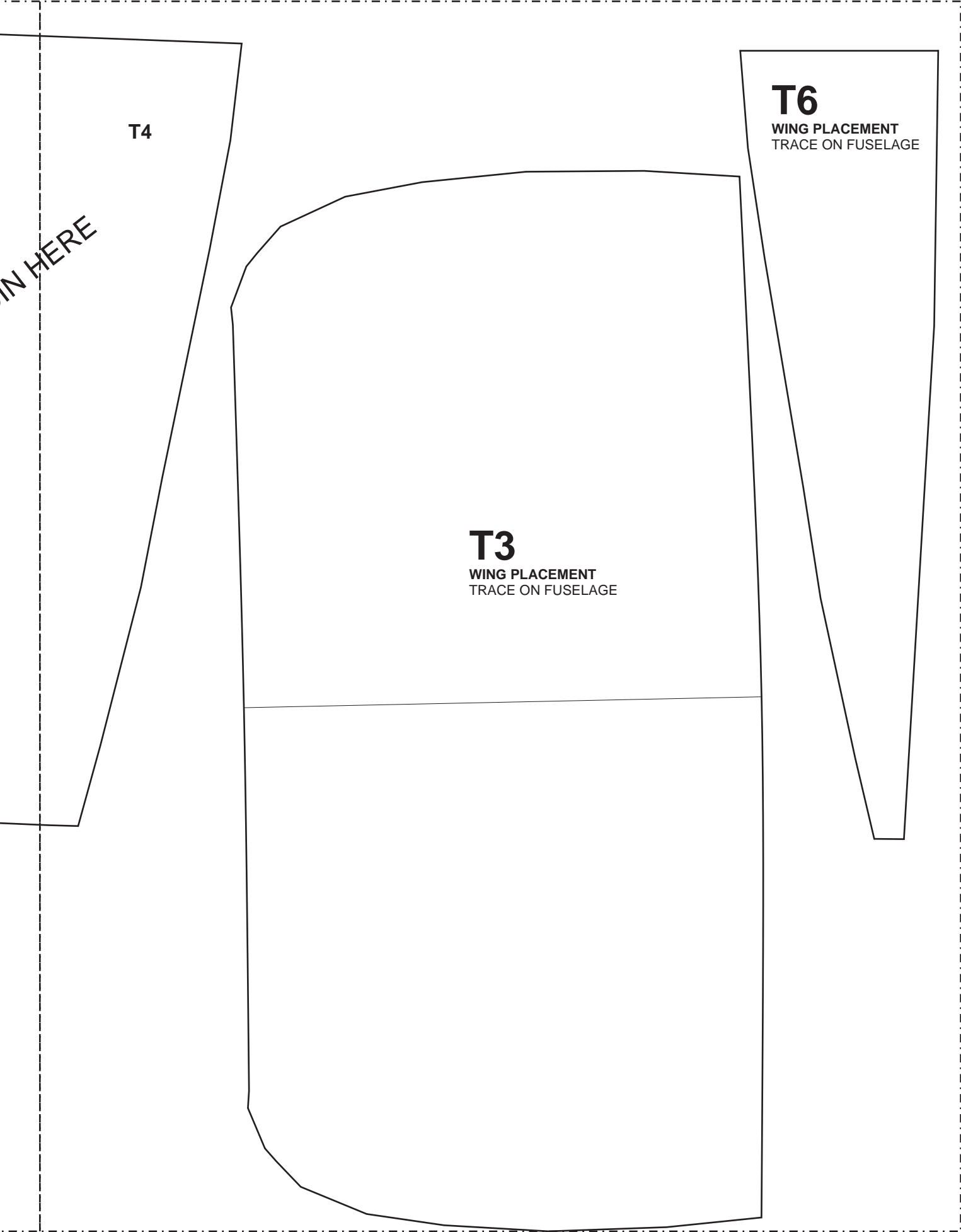

**T4**

**T6**

WING PLACEMENT  
TRACE ON FUSELAGE

**T3**

WING PLACEMENT  
TRACE ON FUSELAGE

IN HERE

**S2**

HORIZONTAL STAB  
DEPRON/POLYFOAM  
5MM

**S3**

ELEVATOR  
DEPRON/POLYFOAM  
5MM  
2X

JOIN HERE

JOIN HERE

S2

**S4**

RUDDER  
DEPRON/POLYFOAM  
5MM  
2X

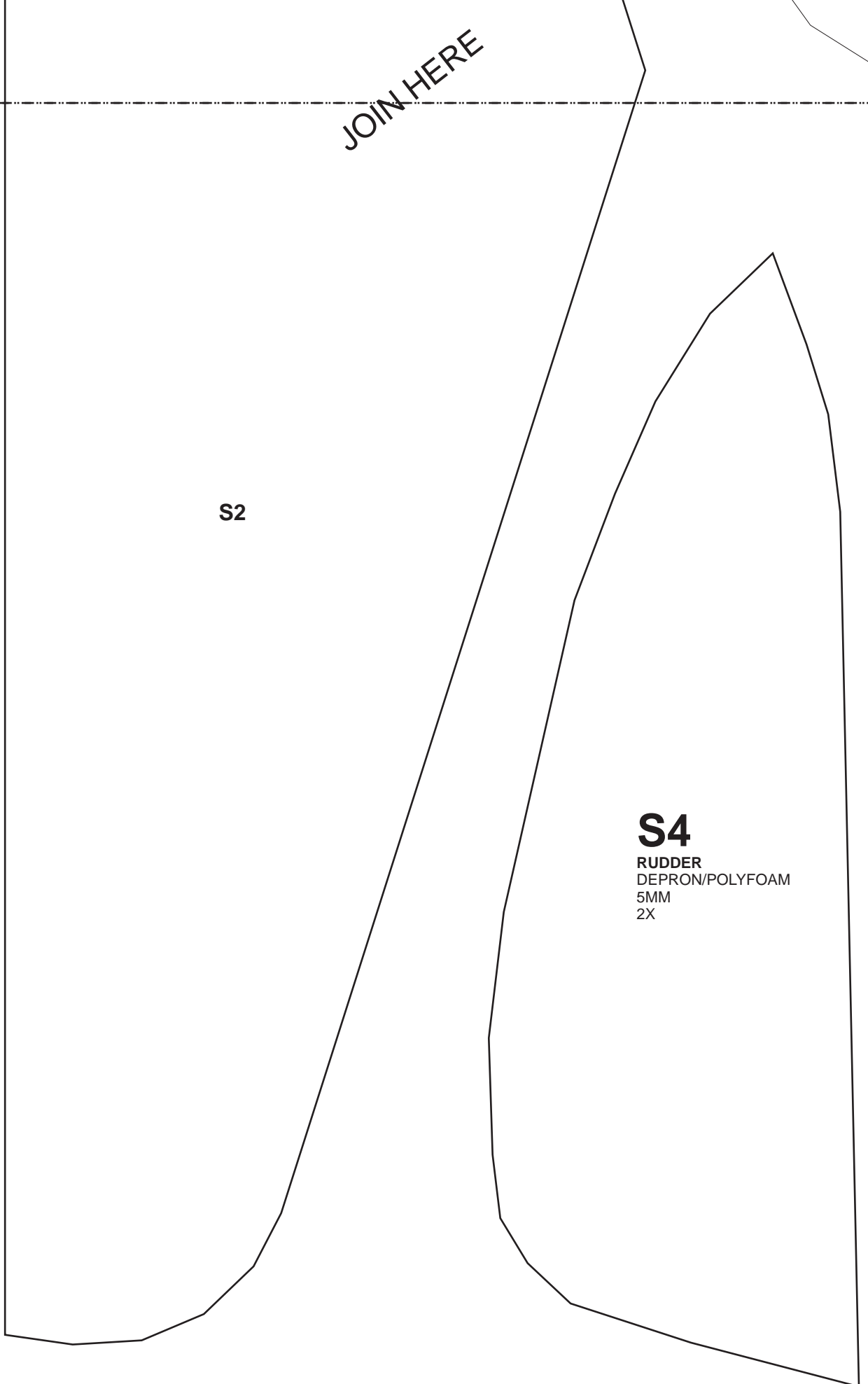



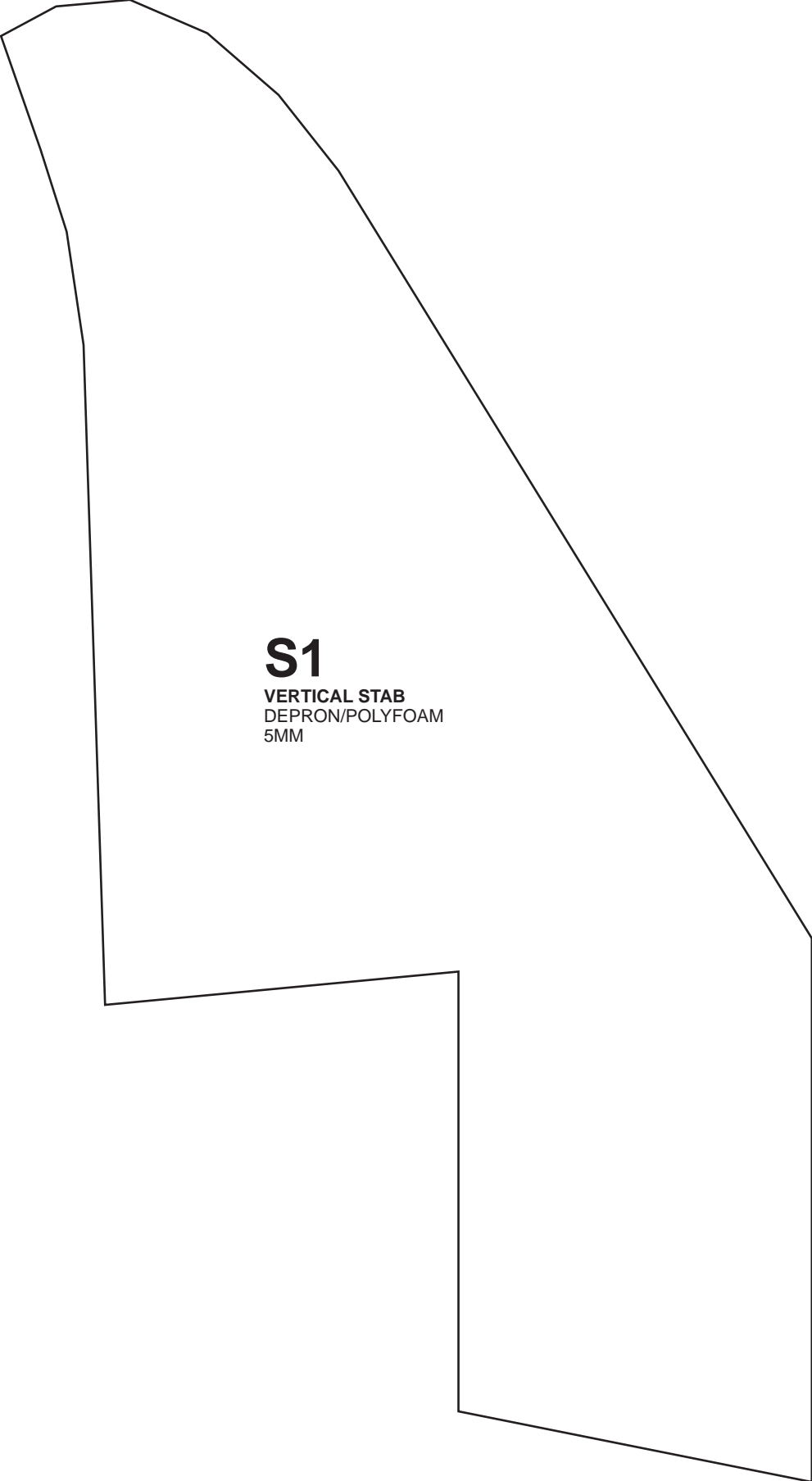

**S1**  
VERTICAL STAB  
DEPRON/POLYFOAM  
5MM

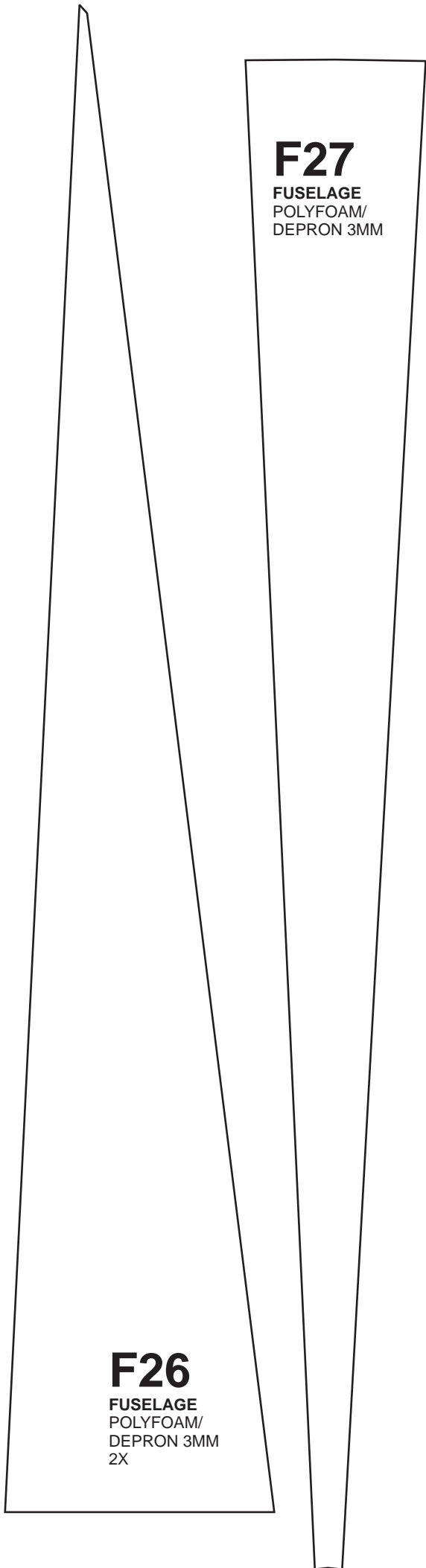

**F27**

FUSELAGE  
POLYFOAM/  
DEPRON 3MM

**F26**

FUSELAGE  
POLYFOAM/  
DEPRON 3MM  
2X

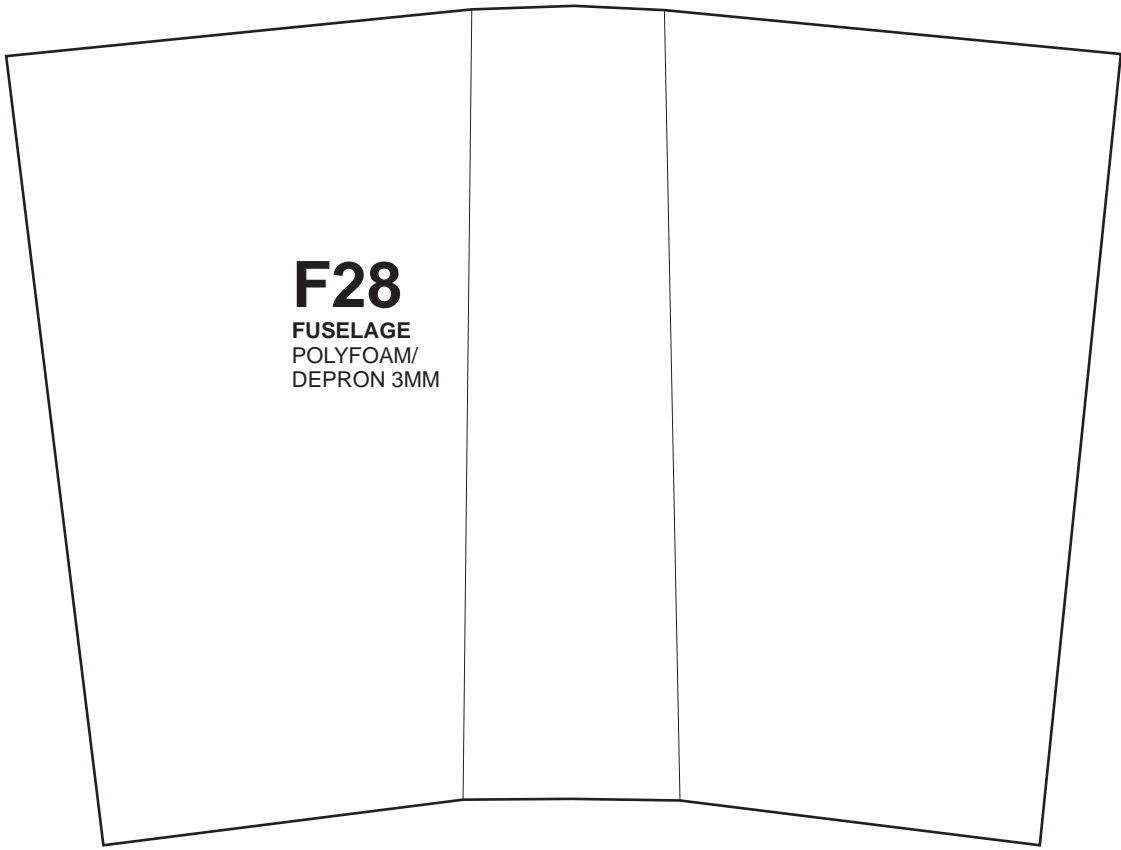

Roll to shape  
an 50 cal MG barrel

Roll to shape  
an 50 cal MG barrel

Roll to shape  
an 50 cal MG barrel

MG Base

MG Base

Roll to shape  
an 50 cal MG barrel

Roll to shape  
an 50 cal MG barrel

Roll to shape  
an 50 cal MG barrel

**C1**  
CANOPY  
MICA PLASTIC 0.3MM



**C3**  
CANOPY  
MICA PLASTIC  
0.3MM

**C2**  
CANOPY  
MICA PLASTIC 0.3MM

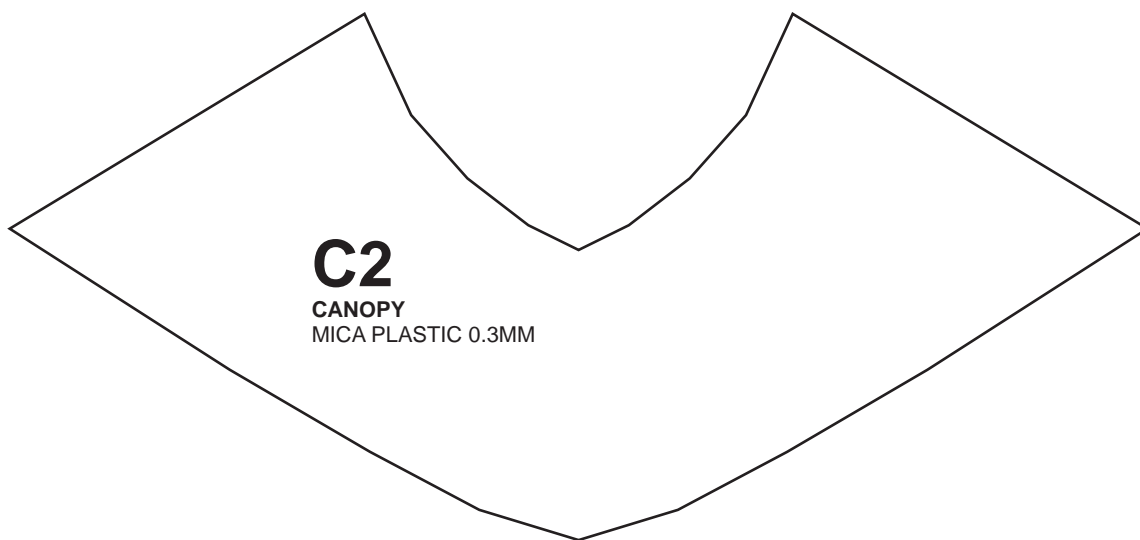

# PAPERCRAFT TEMPLATE

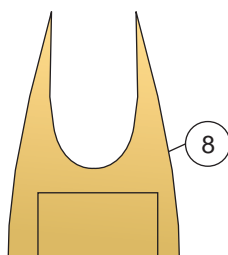
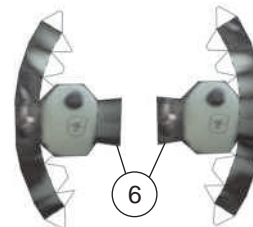
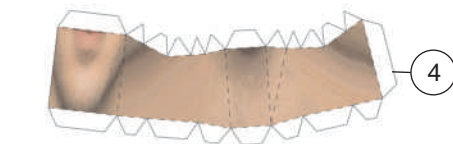
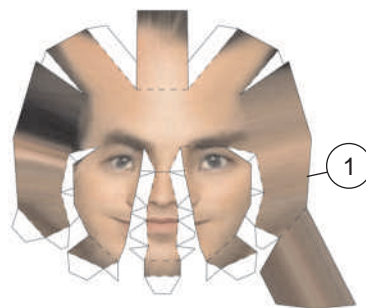
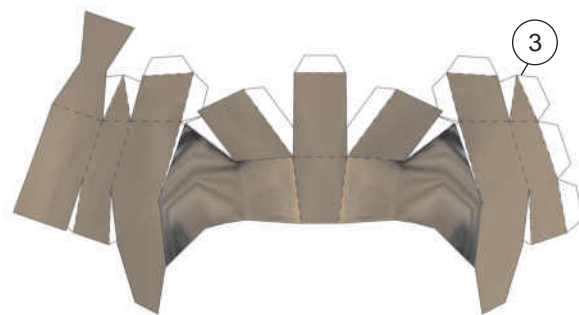
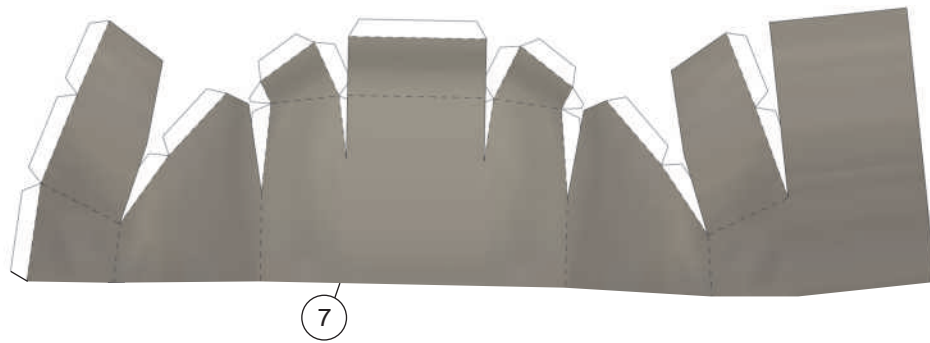

**PRINT ON :**  
80 gram - Difficulty Hard  
100 gram - Medium  
160 gram - Normal

JOIN HERE

JOIN HERE

**F29**

WING FAIRING  
MICA PLASTIC  
0.3MM

**F29**

WING FAIRING  
MICA PLASTIC  
0.3MM

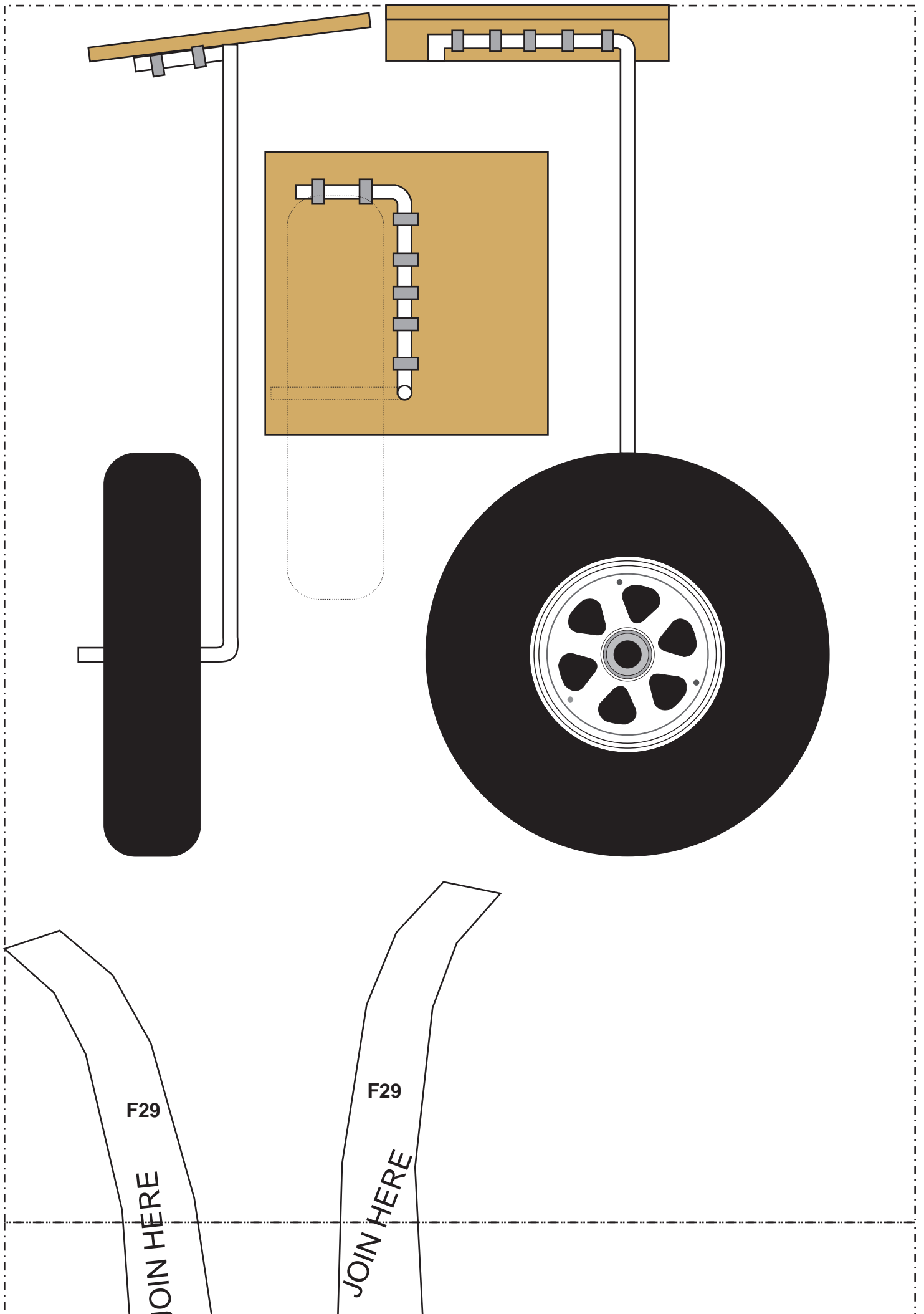



**D4**

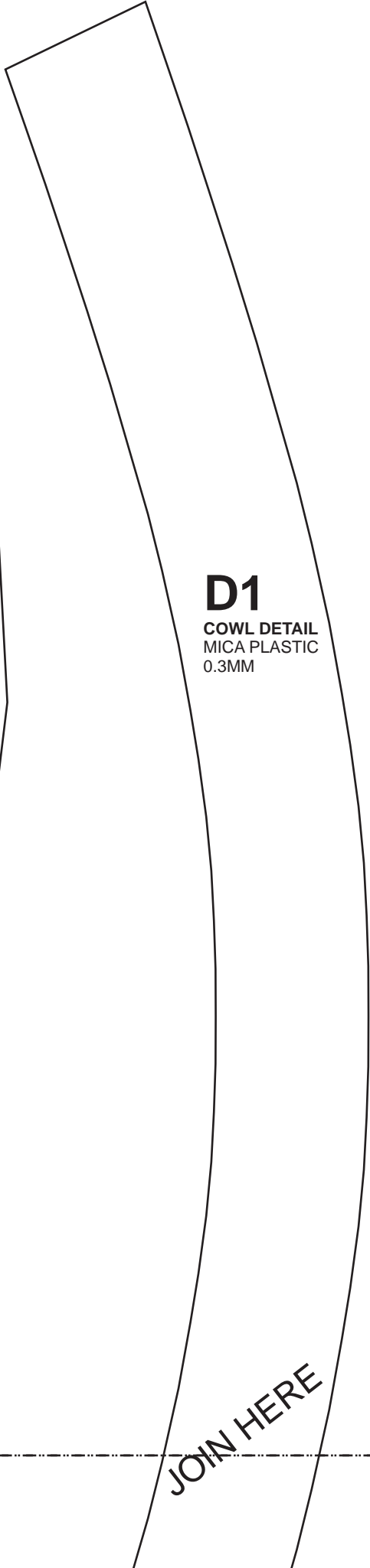

**D1**

**COWL DETAIL**  
MICA PLASTIC  
0.3MM

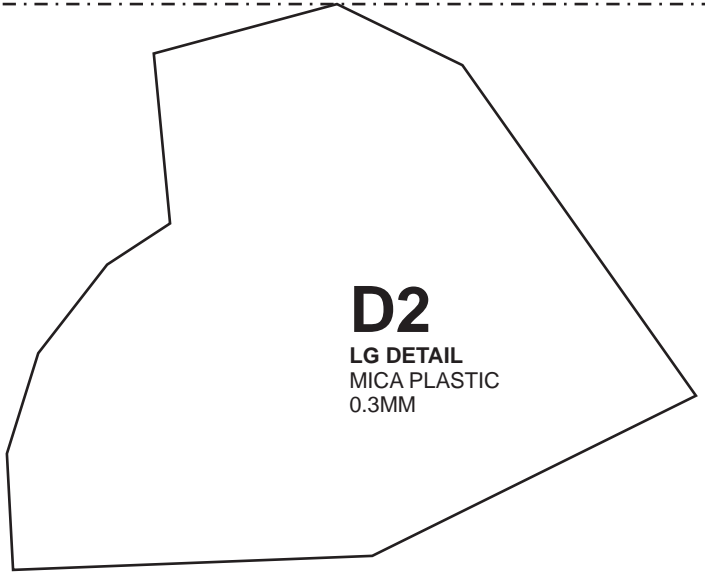

**D2**

**LG DETAIL**  
MICA PLASTIC  
0.3MM

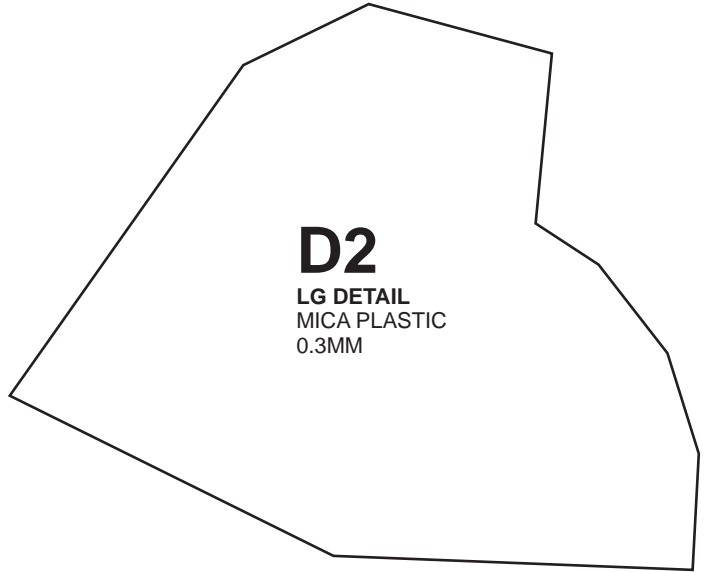

**D2**

**LG DETAIL**  
MICA PLASTIC  
0.3MM



**D3**

**LG DETAIL**  
MICA PLASTIC  
0.3MM



**D3**

**LG DETAIL**  
MICA PLASTIC  
0.3MM

**JOIN HERE**



JOIN HERE

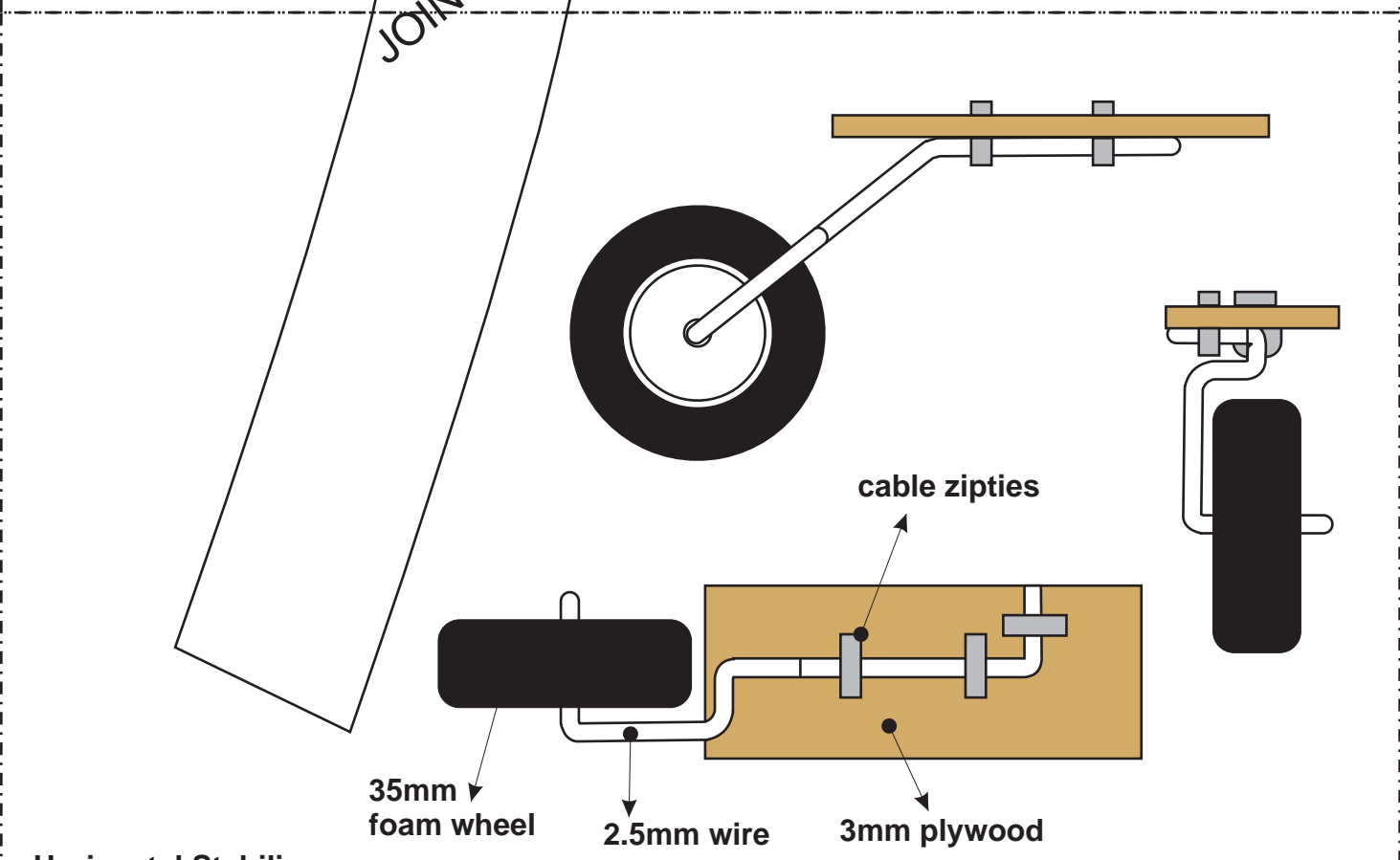

Horizontal Stabilizer

F17

F16

