



Model : 30/2021



MQ-9 REAPER UAV

2500mm

Specs :

1. Wingspan 2500 mm / 98.4 inches
2. Flying weight : 1800 grams/ 63.5 oz
3. Wing loading : 33.7 gram/dm² - 11 oz/sq.ft.
4. Wing cube loading : 4.6
5. Wing Area : 53.46 dm² / 829 sq.in.
6. CG : 8 cm / 3.14 inch from LE (leading edge on root chord)

Electronics

- DXW 3536 1200kv
- 50A ESC
- Battery Lipo 3S 2200mah
- 3 x 9 gram servos (micro servo)
- 1 X standard servo
- 50mm, 60mm foam wheels

Materials :

1. 5mm + 3mm Foamboard/ Depron/ Polyfoam
2. 3mm + 9mm Plywood
3. 0.1mm Mica Plastic
4. hot glue, UHU glue, CA glue
5. laminating film

Build Instructions :

1. paper-replika.com
2. youtube channel : Julius Perdana

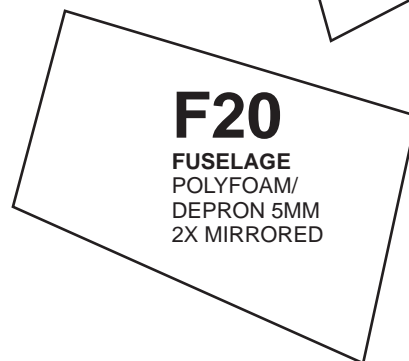
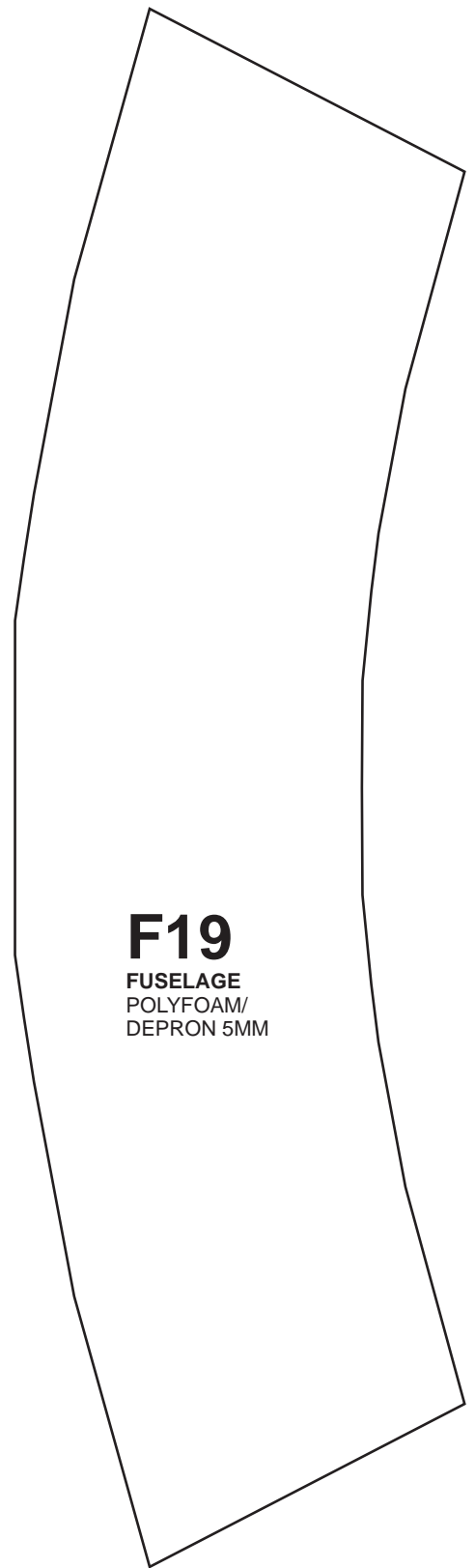
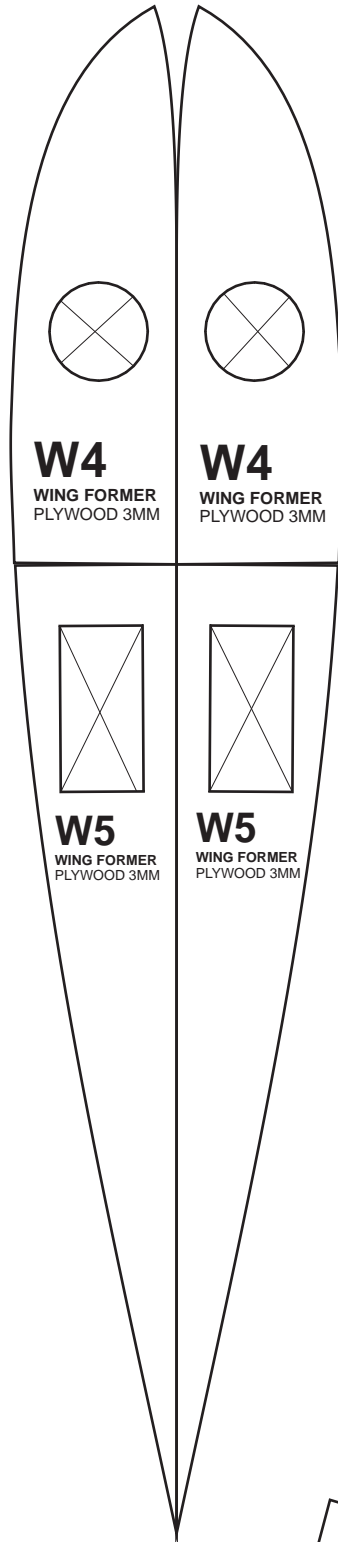
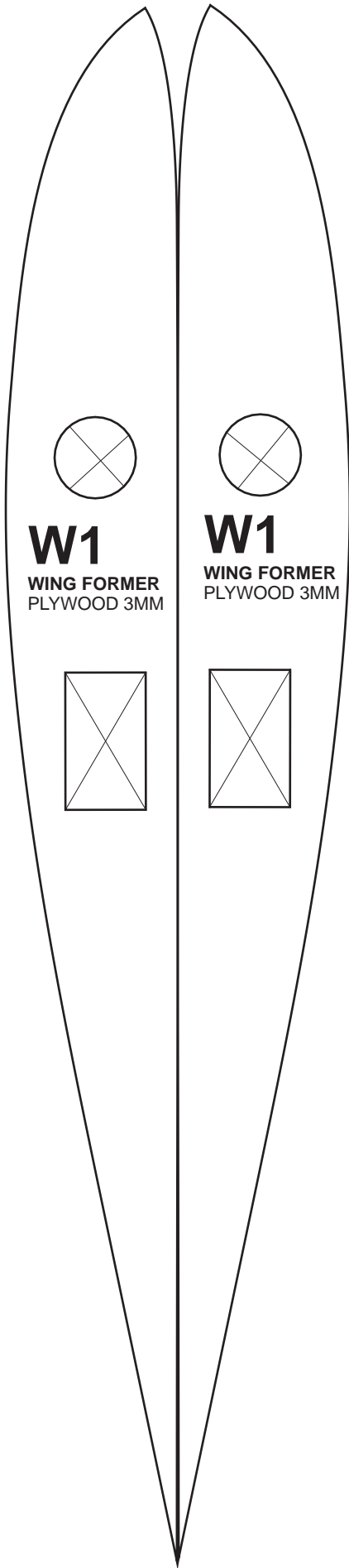

PYLON

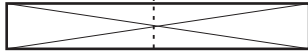

JOIN HERE

W2

WING
POLYFOAM/
DEPRON 5MM
2X MIRRORED

CG

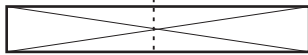

FRONT



W HERE

PYLON

W2

JOIN HER

JOIN HERE

W2

JOIN HERE



JOIN HERE

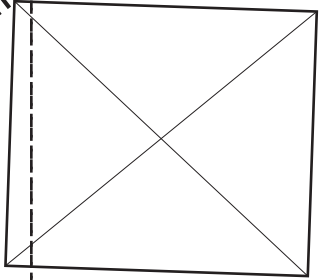

W2

JOIN HERE

JOIN HERE

JOIN HERE

W2

F21
FUSELAGE
POLYFOAM/
DEPRON 5MM

HERE

W2

F22

FUSELAGE
POLYFOAM/
DEPRON 3MM

JOIN HERE

JOIN HER



FRONT

W8

WING
POLYFOAM/
DEPRON 5MM
2X MIRRORED

JOIN HER

JOIN HERE

JOIN HERE

JOIN HERE

JOIN HERE

W8

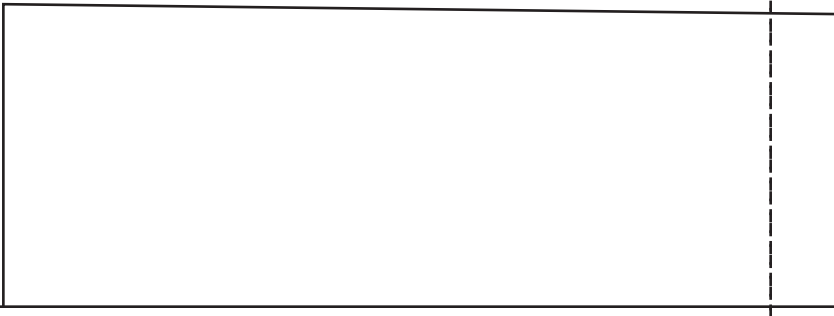

JOIN HERE

W8

JOIN HERE

JOIN HERE

JOIN HERE

W8

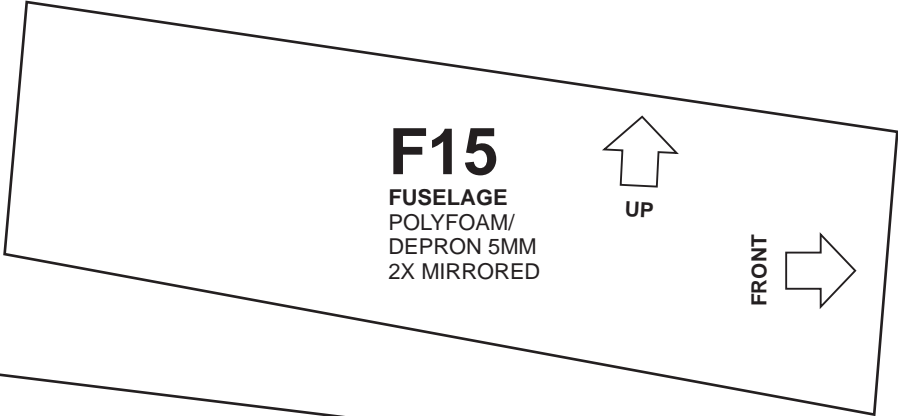

F15

FUSELAGE
POLYFOAM/
DEPRON 5MM
2X MIRRORED



UP

FRONT



JOIN HERE

W8

JOIN HERE

JOIN HERE

W8



W6

WINGTIP
POLYFOAM/
DEPRON 3MM
2X MIRRORED



W7

WINGTIP
POLYFOAM/
DEPRON 3MM
2X MIRRORED

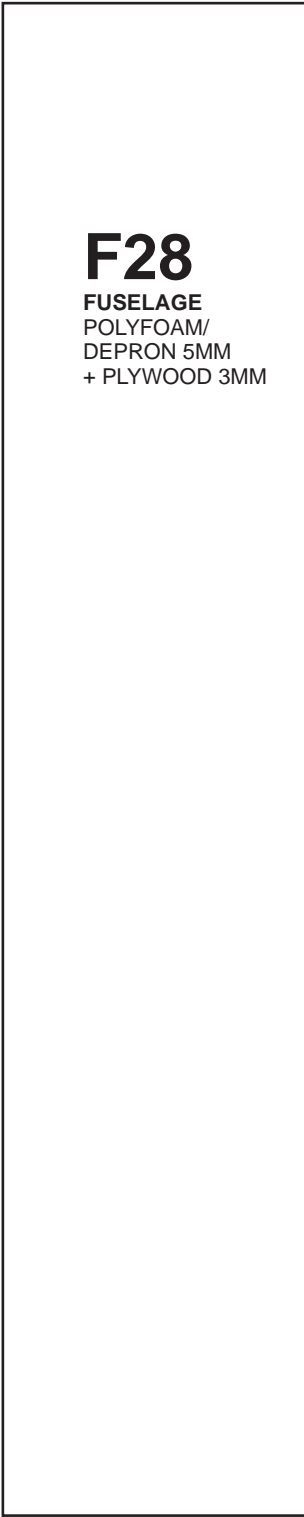

F28

FUSELAGE
POLYFOAM/
DEPRON 5MM
+ PLYWOOD 3MM

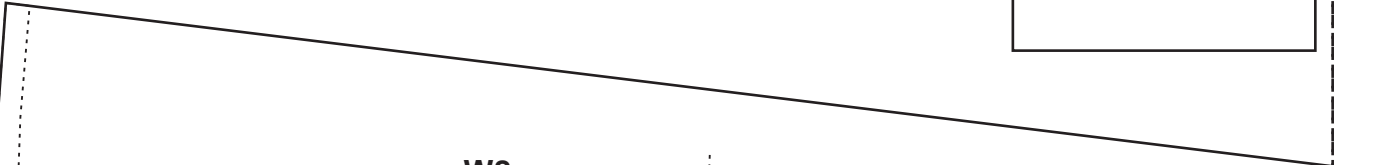

W8

JOIN HERE



JOIN HERE

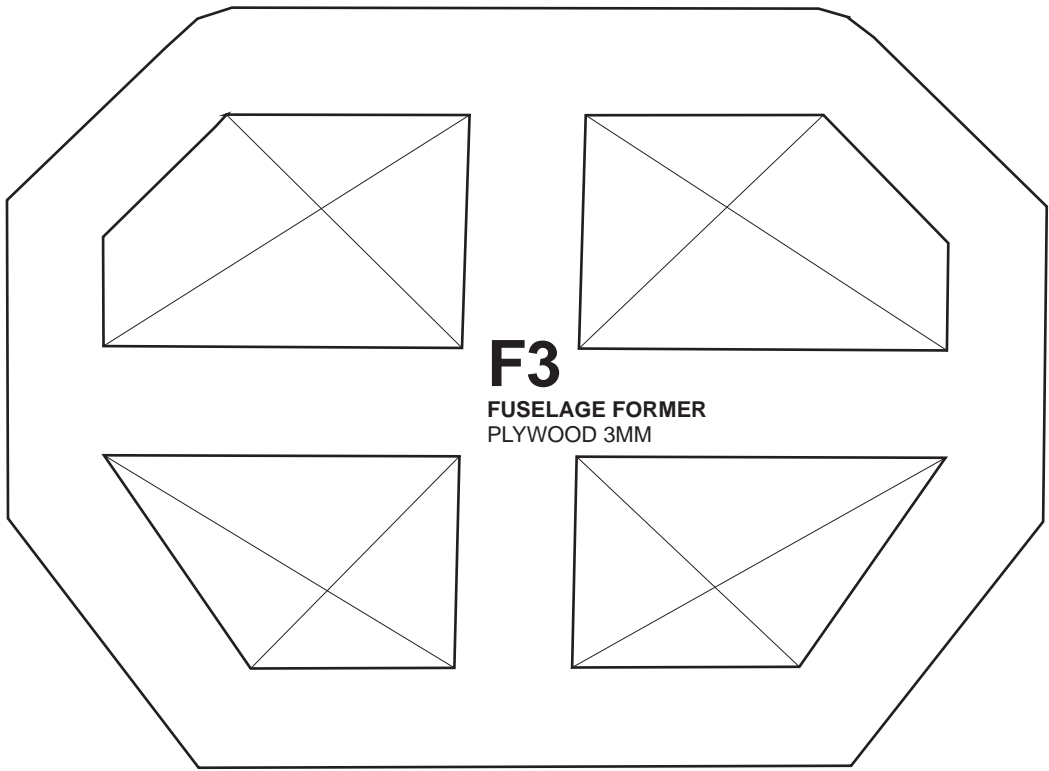

F3

FUSELAGE FORMER
PLYWOOD 3MM

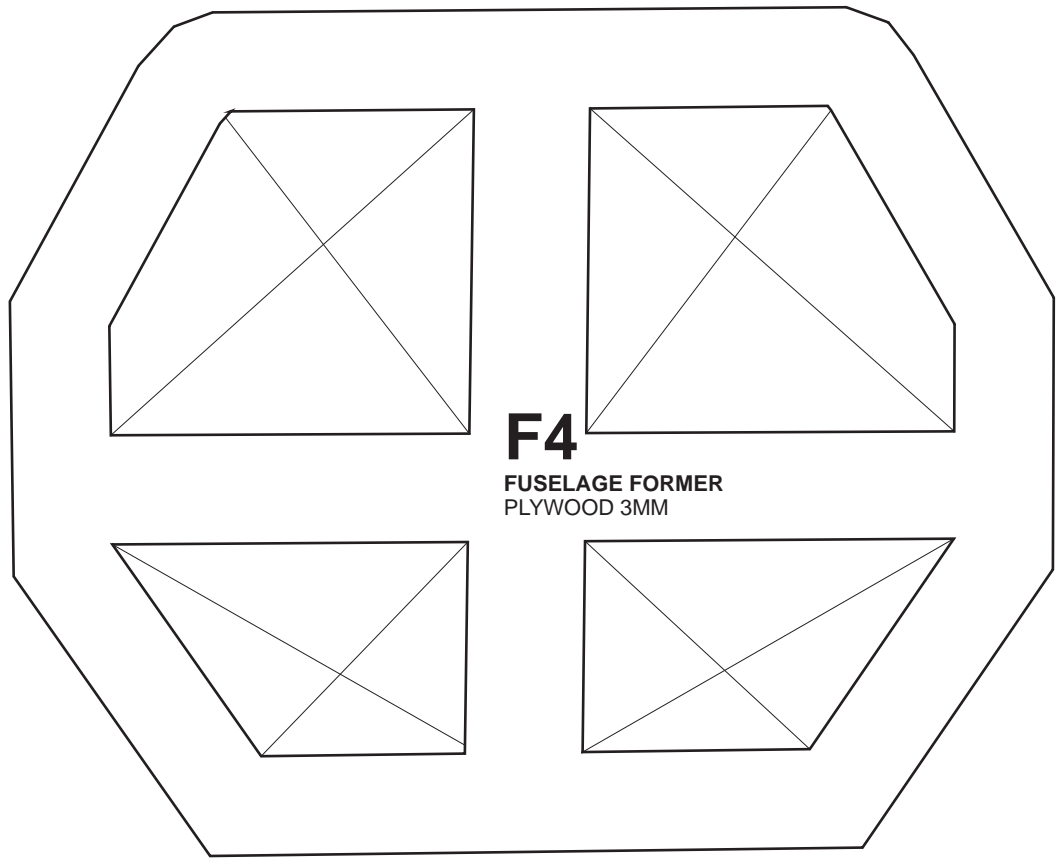

F4

FUSELAGE FORMER
PLYWOOD 3MM

JOIN HERE

W8

JOIN HERE

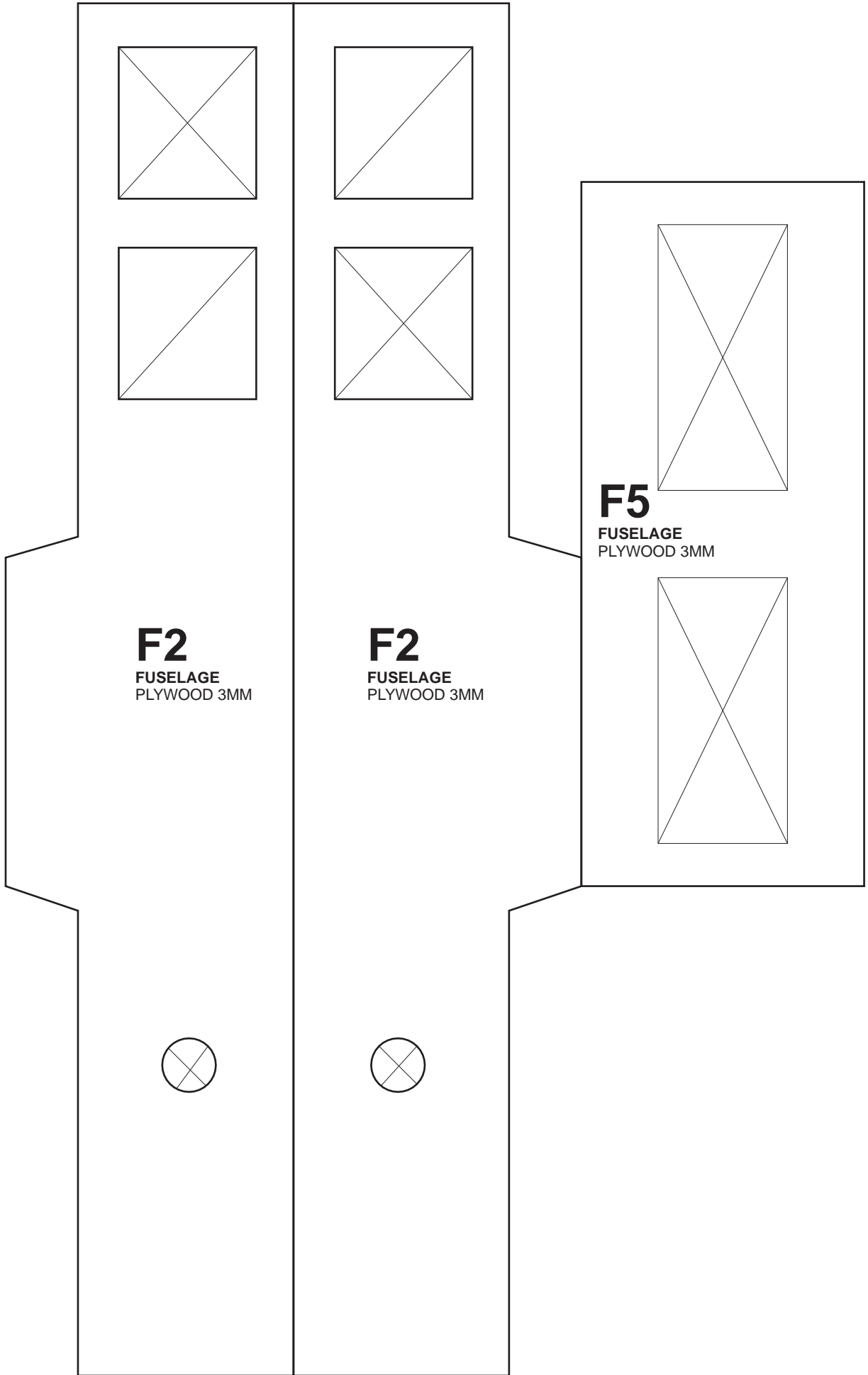

G2

LG BASE
PLYWOOD 3MM

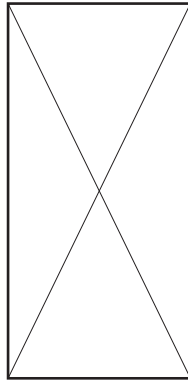

F5

FUSELAGE
PLYWOOD 3MM

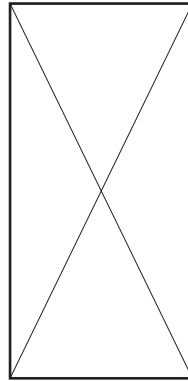

F5

FUSELAGE
PLYWOOD 3MM

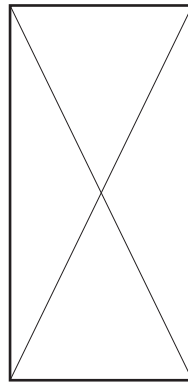
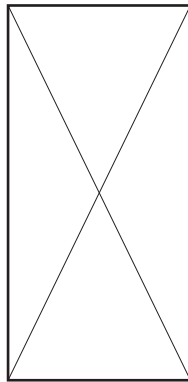

G1

LG BASE
PLYWOOD 3MM

F17

MOTOR MOUNT
PLYWOOD 3MM

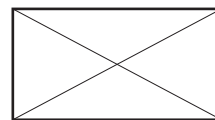

F7

FUSELAGE
POLYFOAM/
DEPRON 5MM

F6

FUSELAGE
POLYFOAM/
DEPRON 5MM
2X MIRRORED

W3

WING SPAR
PLYWOOD 3MM
2X

JOIN HERE

JOIN HERE

F7

F6

W3

JOIN HERE

JOIN HERE

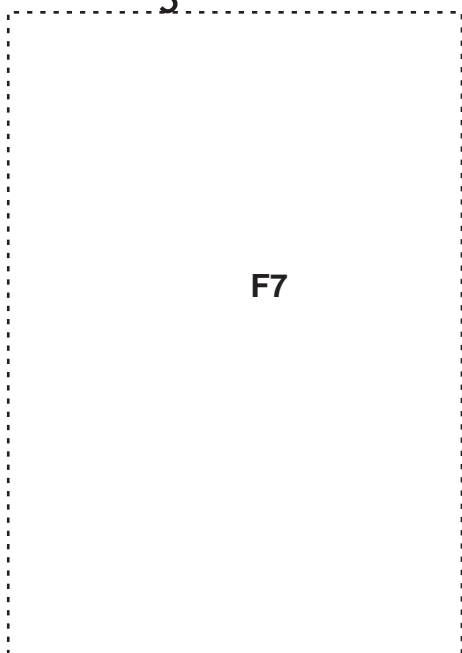

F7

F6

FRONT

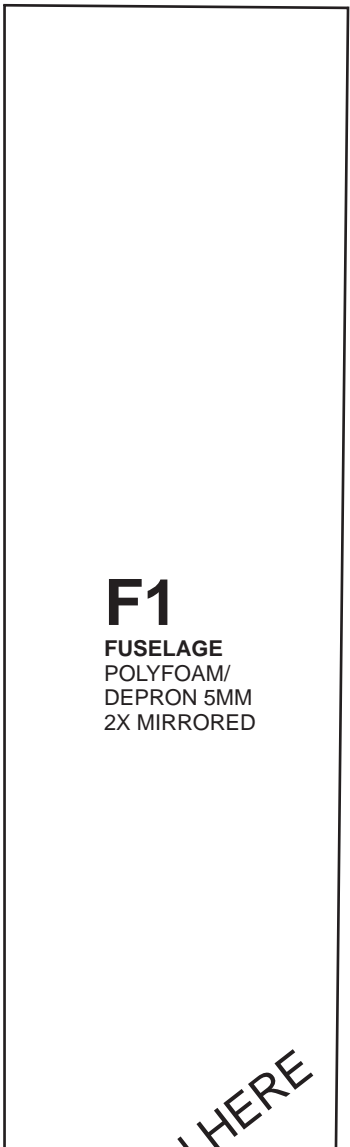

F1
FUSELAGE
POLYFOAM/
DEPRON 5MM
2X MIRRORED

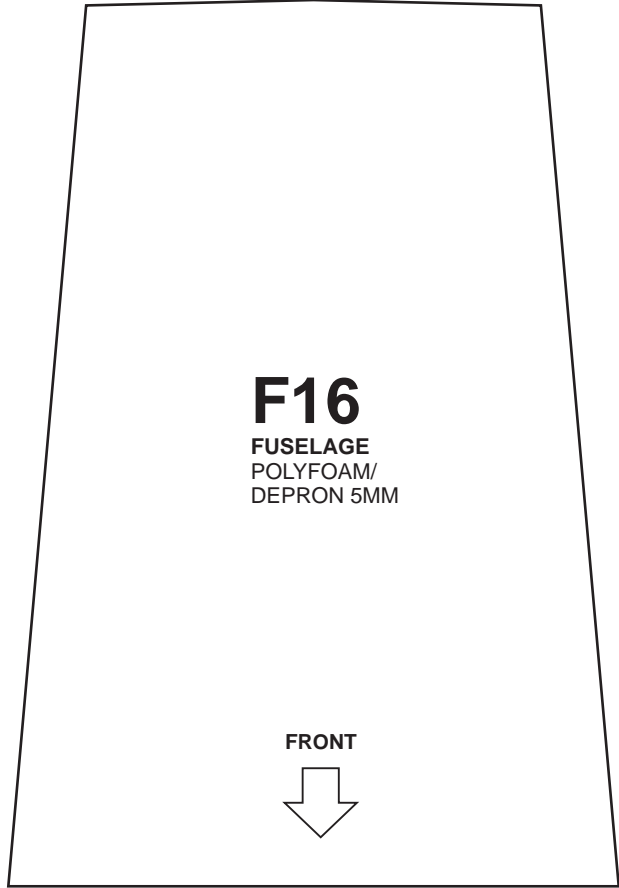

F16
FUSELAGE
POLYFOAM/
DEPRON 5MM

FRONT



W3

JOIN HERE

JOIN HERE

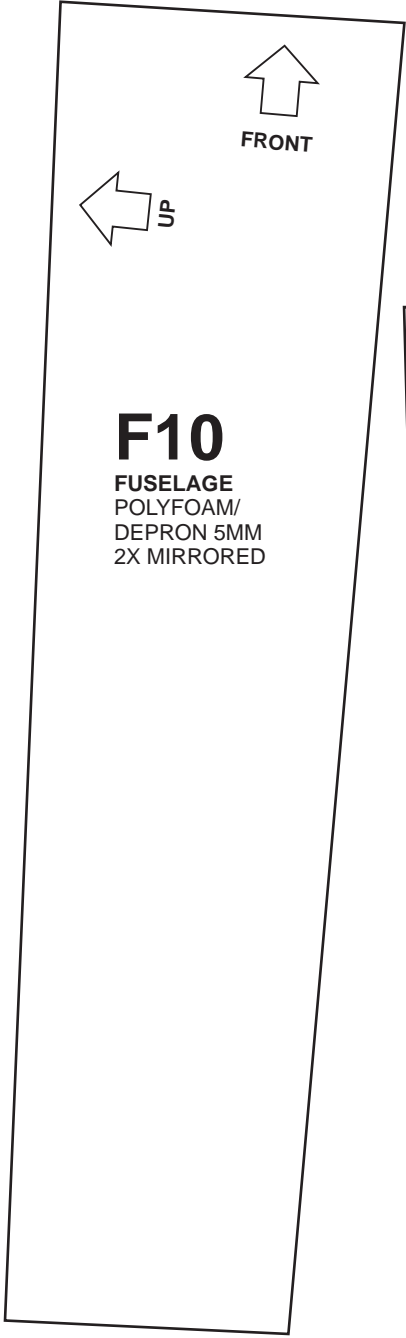

F10
FUSELAGE
POLYFOAM/
DEPRON 5MM
2X MIRRORED

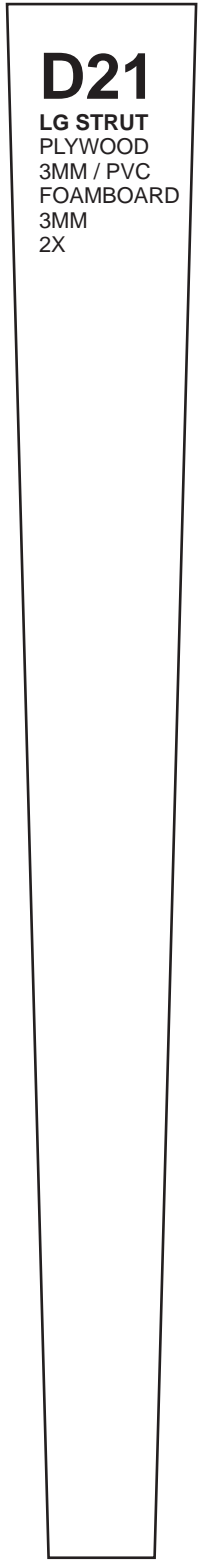

D21
LG STRUT
PLYWOOD
3MM / PVC
FOAMBOARD
3MM
2X

F1

W3



JOIN HERE

JOIN HERE

F1

F11
FUSELAGE
POLYFOAM/
DEPRON 5MM

W3

FRONT



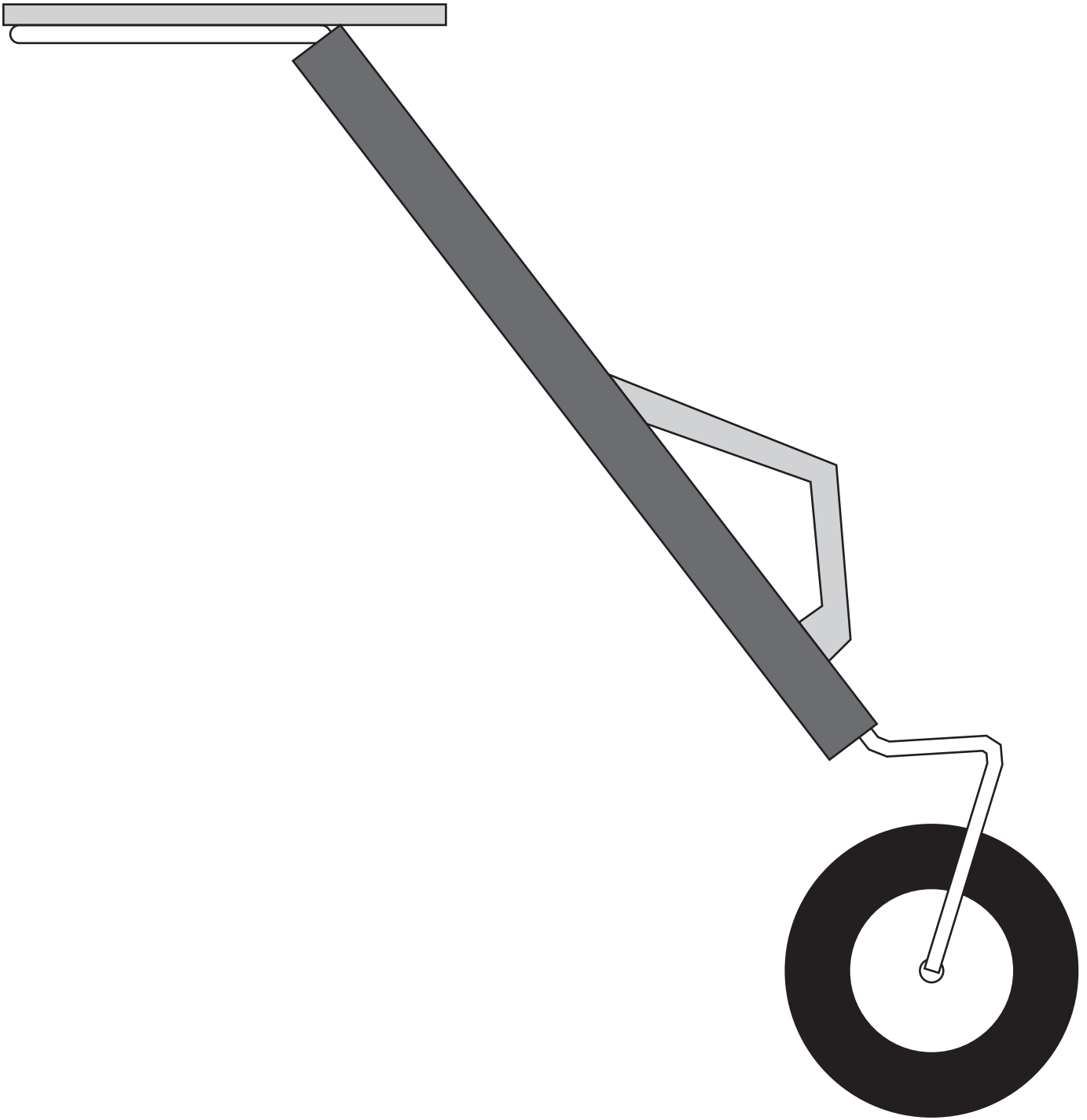





FRONT

F8

FUSELAGE
POLYFOAM/
DEPRON 5MM

JOIN HERE

HERE

F8

JOIN H

JOIN HERE

F8

JOIN HER

JOIN HERE

F8

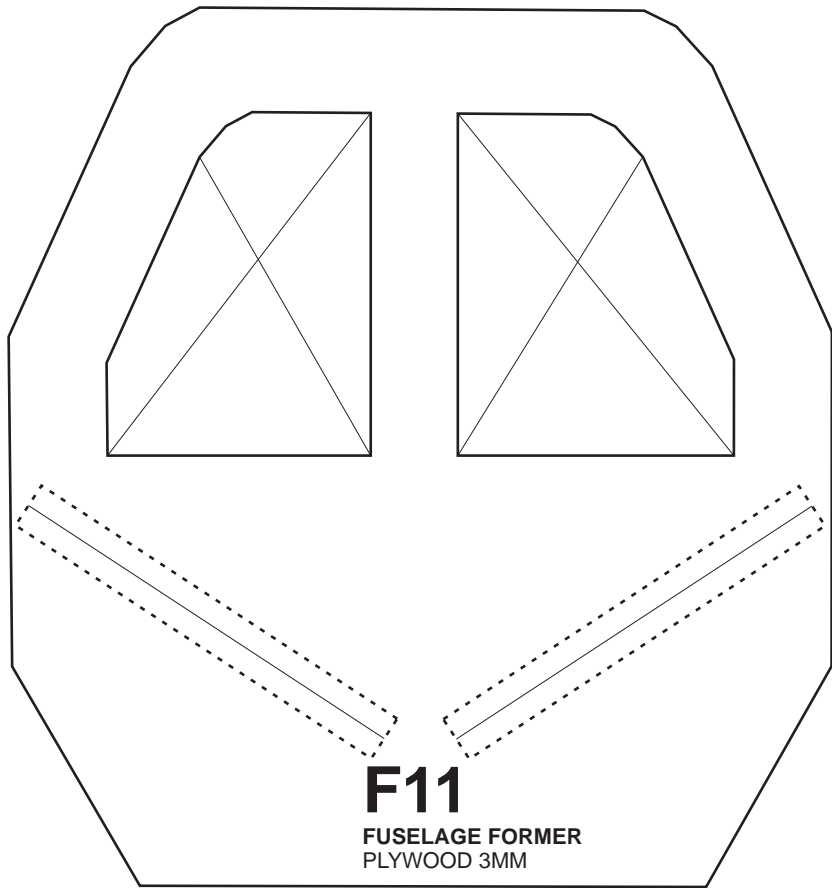

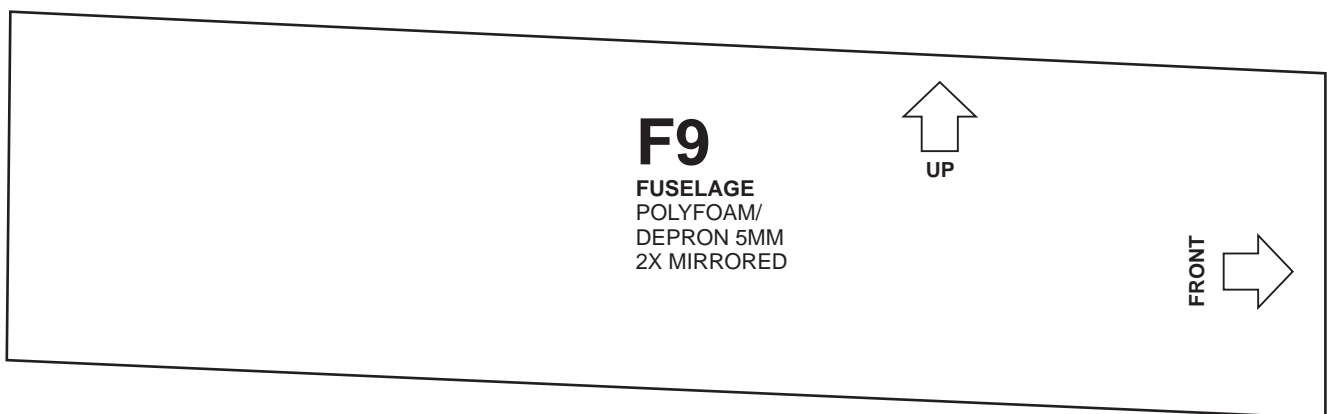
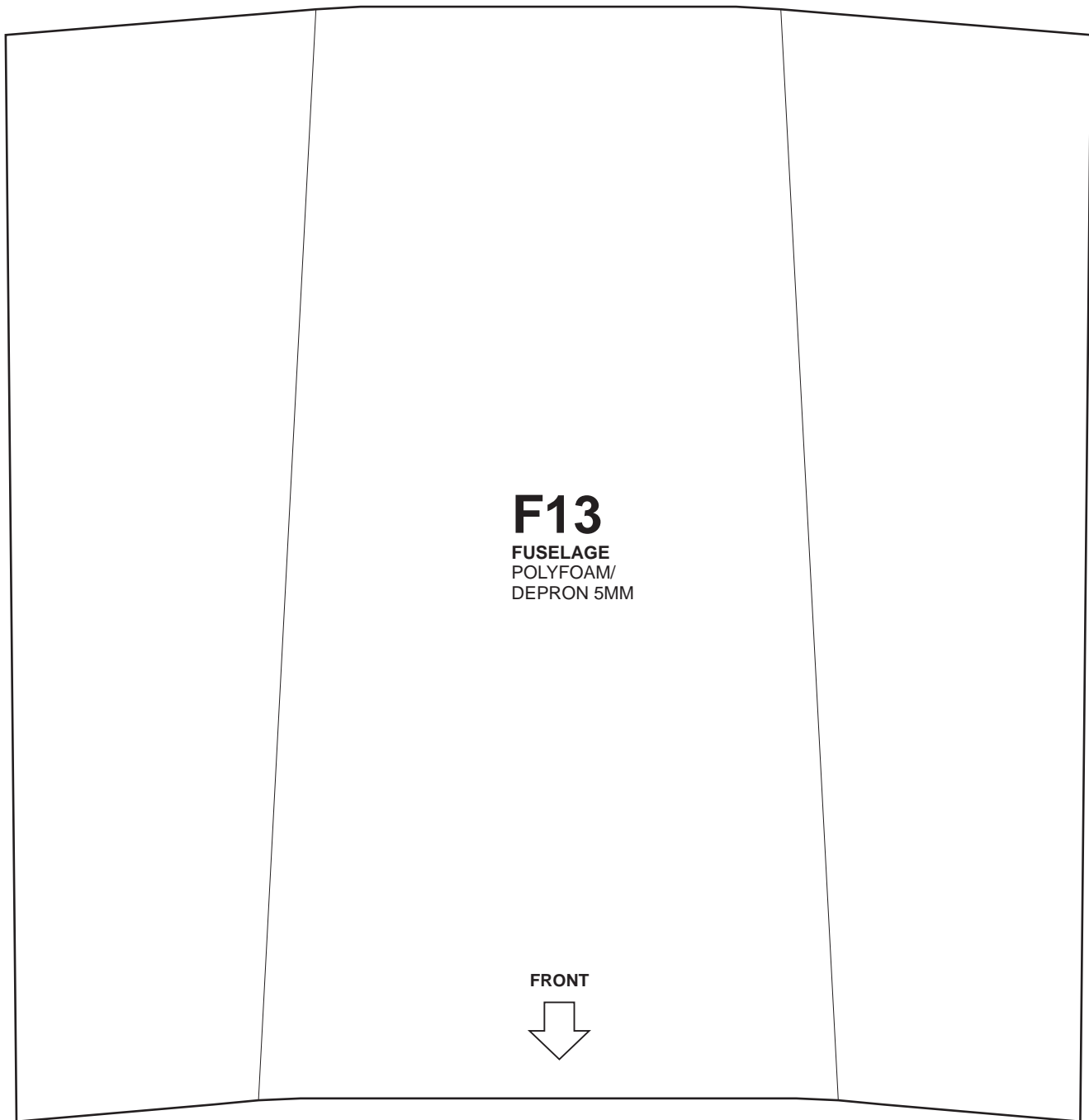

S1

V-STAB
POLYFOAM/
DEPRON 3MM
4X MIRRORED

JOIN HERE

JOIN HERE

S1

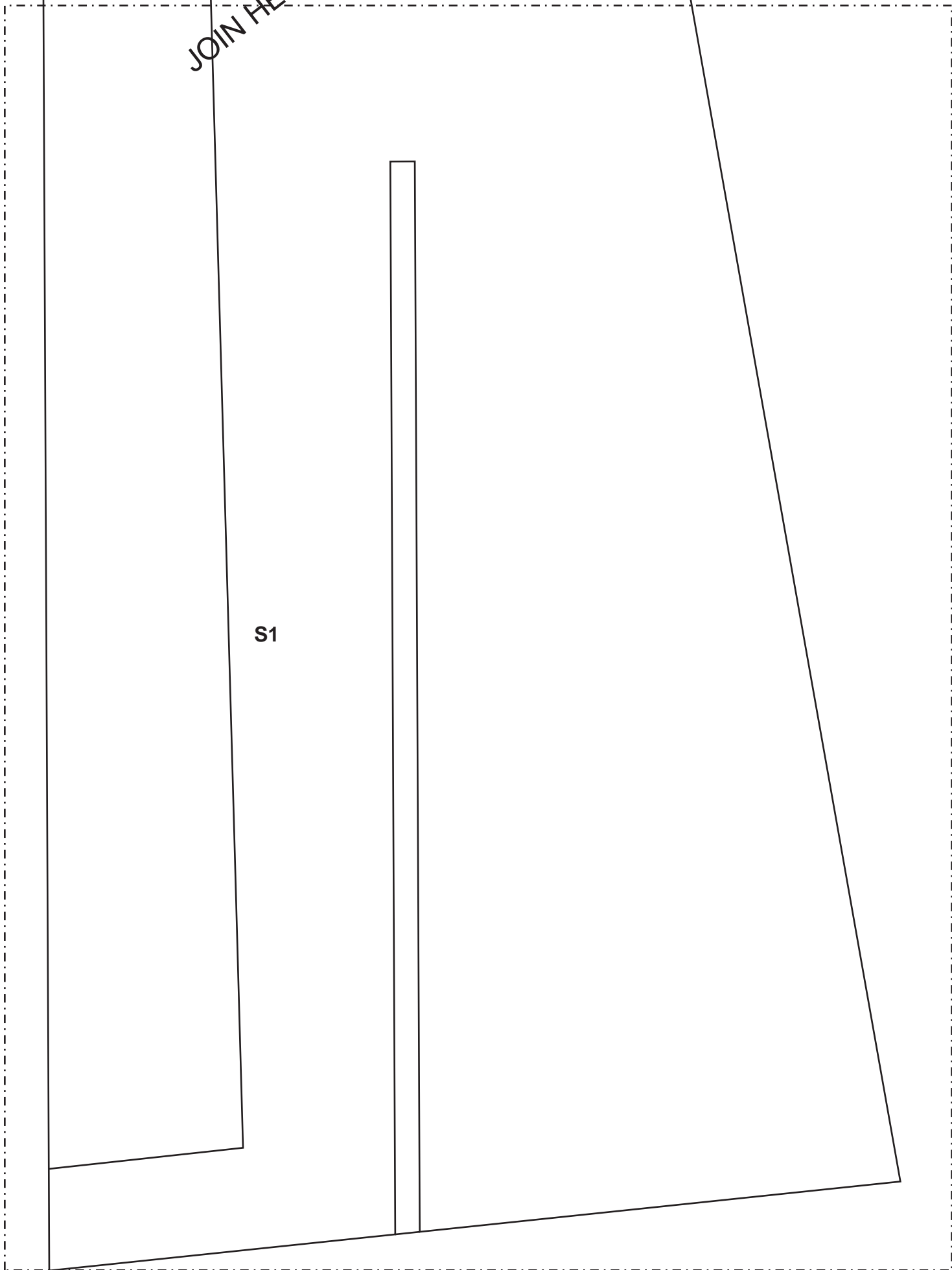

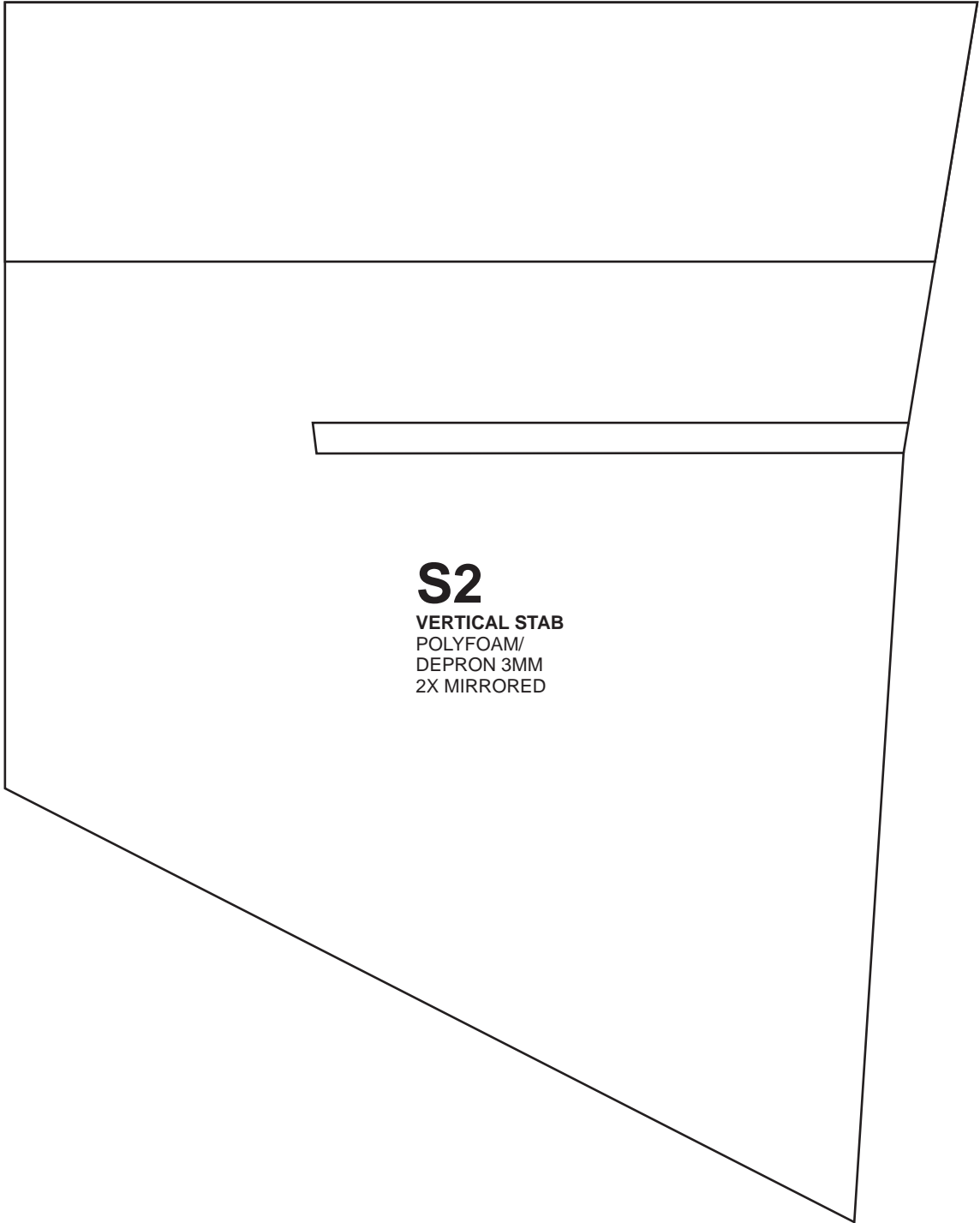

S2

VERTICAL STAB
POLYFOAM/
DEPRON 3MM
2X MIRRORED

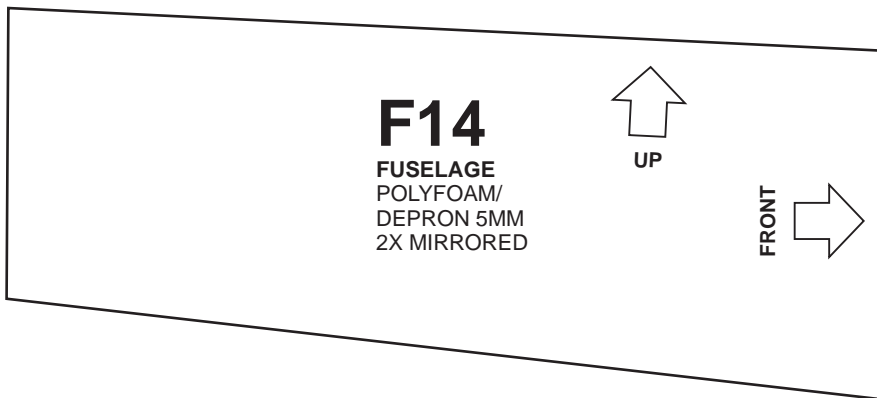
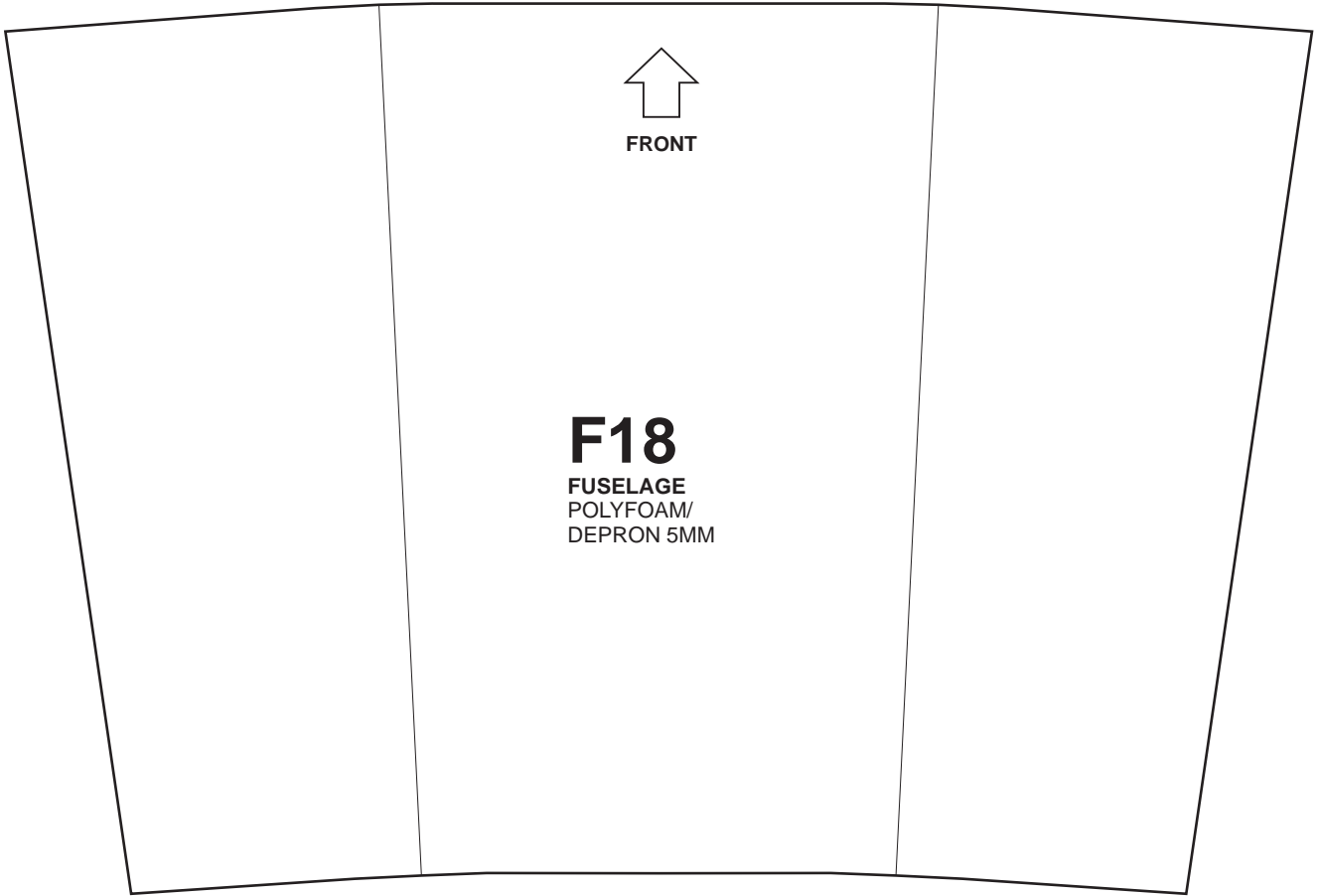

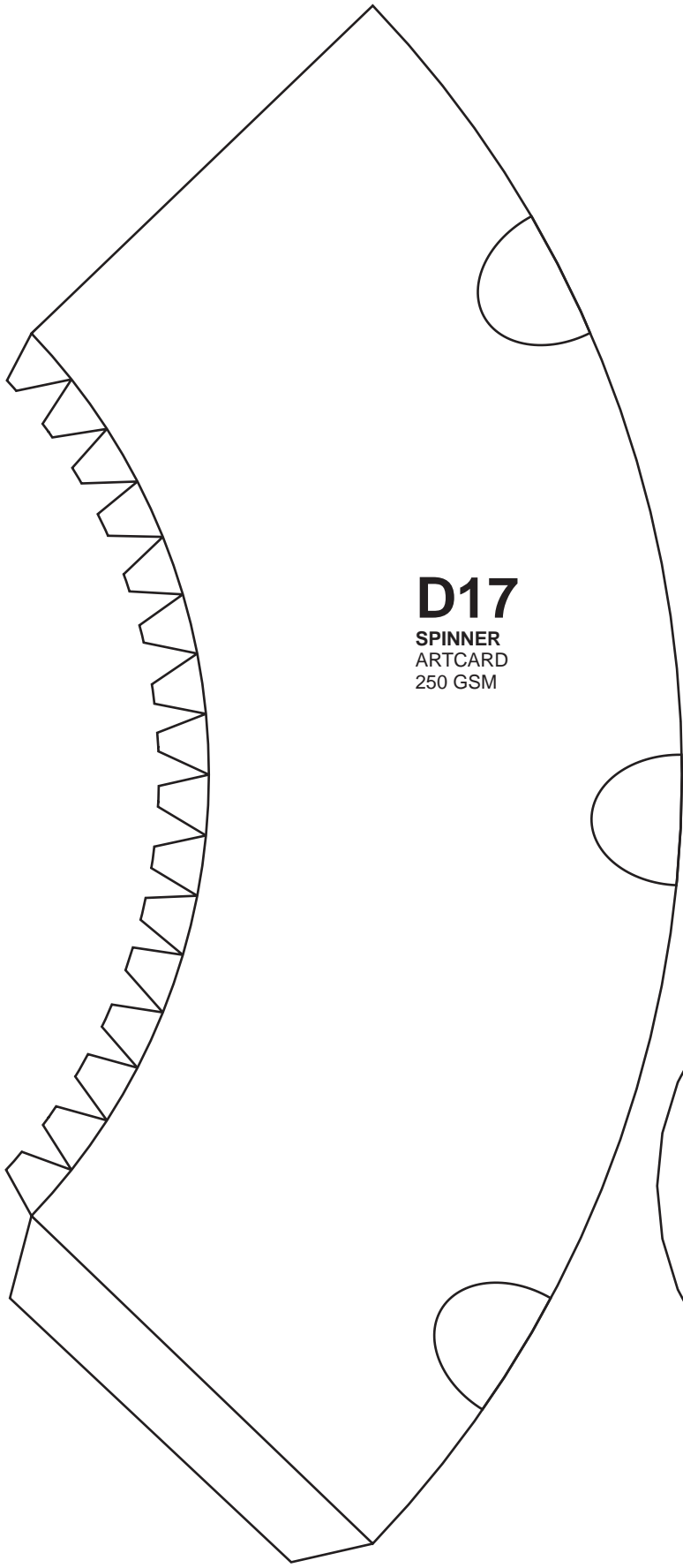

D17
SPINNER
ARTCARD
250 GSM

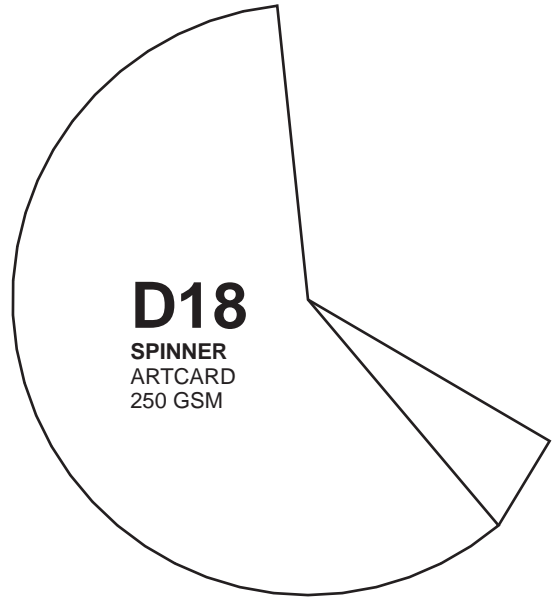

D18
SPINNER
ARTCARD
250 GSM

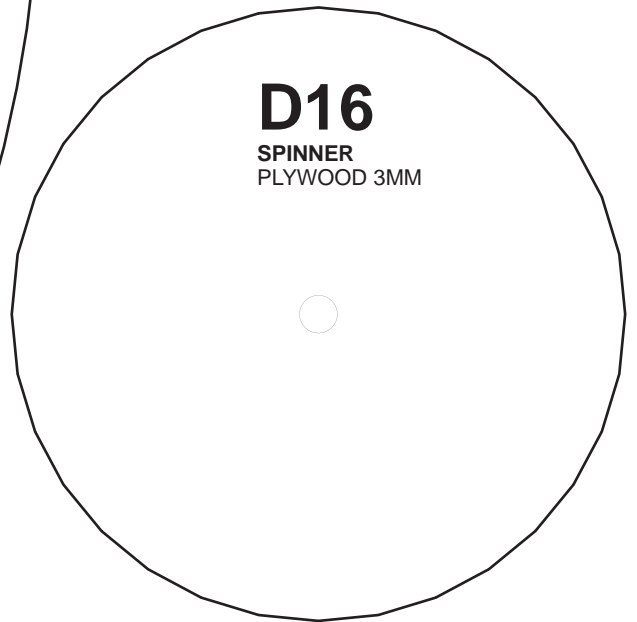

D16
SPINNER
PLYWOOD 3MM

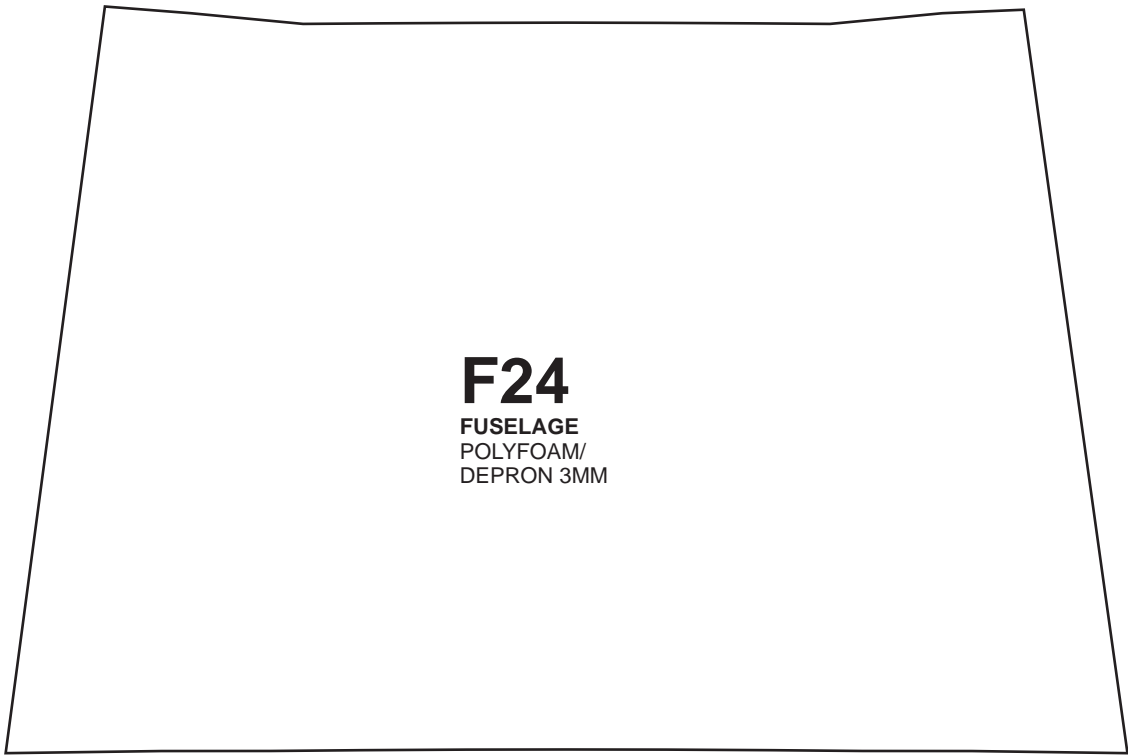

F24

FUSELAGE
POLYFOAM/
DEPRON 3MM



F25

FUSELAGE
POLYFOAM/
DEPRON 3MM



F23

FUSELAGE
POLYFOAM/
DEPRON 3MM

F27
FUSELAGE
POLYFOAM/
DEPRON 5MM

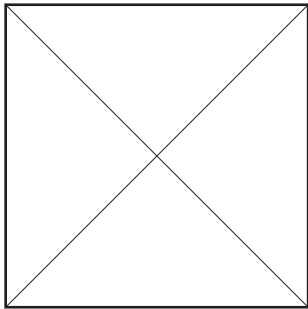

JOIN HERE

F26
FUSELAGE
POLYFOAM/
DEPRON 5MM
2X MIRRORED

JOIN HERE

JOIN HERE

F27

JOIN HERE

F26



F32
FUSELAGE
POLYFOAM/
DEPRON 5MM



F29
FUSELAGE
POLYFOAM/
DEPRON 5MM
2X MIRRORED

JOIN HERE

JOIN HERE

JOIN HERE

F32

JOIN HERE

F29

F31
FUSELAGE
POLYFOAM/
DEPRON 5MM
2X MIRRORED

F30
FUSELAGE
POLYFOAM/
DEPRON 5MM
2X MIRRORED

JOIN HERE

JOIN HERE

JOIN HERE

F31

JOIN HERE

F30

